

Manuals and Guides 14
Intergovernmental Oceanographic Commission

**Manual on Sea Level
Measurement and Interpretation**

Volume IV: An Update to 2006

JCOMM Technical Report No. 31
WMO/TD. No. 1339





Intergovernmental Oceanographic Commission (IOC)

United Nations Educational, Scientific and Cultural Organization

1, rue Miollis

75732 Paris Cedex 15, France

Tel: +33 1 45 68 10 10

Fax: +33 1 45 68 58 12

Website: <http://ioc.unesco.org>

Manual on Sea Level Measurement and Interpretation

Volume IV: An Update to 2006



The designations employed and the presentation of the material in this publication do not imply the expression of any opinion whatsoever on the part of the Secretariats of UNESCO and IOC concerning the legal status of any country or territory, or its authorities, or concerning the delimitation of the frontiers of any country or territory.

Layout and design by Eric Loddé

For bibliographic purposes, this document should be cited as follows:

Manual on Sea-level Measurements and Interpretation, Volume IV : An update to 2006. Paris, Intergovernmental Oceanographic Commission of UNESCO. 78 pp. (IOC Manuals and Guides No.14, vol. IV ; JCOMM Technical Report No.31; WMO/TD. No. 1339) (English)

Rev. 2006/09

Printed in 2006

by the United Nations Educational, Scientific and Cultural Organization
7, place de Fontenoy, 75352 Paris 07 SP

© UNESCO 2006

Printed in France

(SC-2006/WS/38)

Table of contents

1. Introduction	1
2. The Nature of Sea Level Variations.....	2
2.1 Introduction	2
2.2 Surface Waves.....	3
2.3 Seiches	4
2.4 Tides	4
2.4.1 Tidal Analysis.....	5
2.5 Storm surges	6
2.6 Tsunamis	7
2.7 Mean Sea Level and Trends	7
2.8 Estimation of Extreme Sea Levels.....	7
2.8.1 Introduction	7
2.8.2 The Annual Maximum Method (AMM).....	8
2.8.3 The Joint Probabilities Method (JPM).....	8
2.8.4 The Revised Joint Probabilities Method (RJPM).....	9
2.8.5 The Exceedance Probabilities Method	9
2.8.6 Spatial Estimation of Extremes	9
3. Instruments for the Measurement of Sea Level	10
3.1 Introduction	10
3.1.1 The Choice of a Tide Gauge Site.....	10
3.2 The Stilling Well	12
3.2.1 Datum Switches.....	12
3.3. Pressure Gauges.....	13
3.3.1 Pneumatic Bubbler Gauges.....	13
3.3.2 Pressure Sensor Gauges.....	14
3.3.3 The Datum of a Pressure System.....	15
3.3.4 Multiple Pressure Transducer Systems ('B' gauges).....	16
3.3.5 Pressure Transducers in Stilling Wells.....	16
3.3.6 Bottom-mounted Pressure Gauges	16
3.4 Acoustic Tide Gauges.....	17
3.4.1 Acoustic Gauges with Sounding Tubes	17
3.4.2 Acoustic Gauges without Sounding Tubes.....	17
3.5 Radar Gauges.....	19
3.6 Summary of the Merits of Different Technologies	21

4. Datum Control and Levelling.....	28
4.1 Datums and Benchmarks.....	28
4.1.1 Tide Gauge Benchmark (TGBM).....	29
4.1.2 GPS Benchmark (GPSBM).....	29
4.1.3 Gauge Contact Point (CP).....	29
4.1.4 Tide Gauge Zero (TGZ).....	29
4.1.5 Revised Local Reference (RLR) Datum.....	29
4.1.6 National Levelling Network.....	29
4.1.7 Chart Datum.....	30
4.1.8 Working Datums.....	30
4.2 Levelling Between Local Benchmarks.....	30
4.3 Levelling Between Wider Area Marks.....	30
4.4 Geodetic Fixing of Tide Gauge Benchmarks.....	31
4.4.1 Introduction.....	31
4.4.2 GPS Measurements.....	32
4.4.3 DORIS Measurements.....	33
4.4.4 Absolute Gravity Measurements.....	33
4.4.5 Geocentric Co-ordinates and Vertical Land Movements of Tide Gauge Benchmarks.....	34
5. Real Time Data Transmission.....	35
5.1 Introduction.....	35
5.2 Choice of a System.....	38
5.3 Data Transmission Systems.....	39
5.3.1 Systems already well established.....	39
5.3.2 Systems now being applied or considered for application <i>in the transmission of sea level data</i>	39
5.3.3 The Global Telecommunications System (GTS).....	41
5.4 Data Transmission Formats.....	41
6. Quality Control of Data.....	42
7. Training Materials and Contacts.....	43
8. New Techniques for Sea Level Measurements.....	45
8.1 GPS on Buoys.....	45
8.2 GNSS Reflectometry.....	46
References.....	48
Appendices.....	52
I. GLOSS Requirements for Tide Gauges.....	52
II. Previous Volumes of the IOC Manual.....	53
III. List of Websites.....	55
IV. List of Acronyms.....	56

V. Contributed Practical Experiences with Various Tide Gauge Technologies.....	58
FLOAT GAUGES IN STILLING WELLS: EXPERIENCE IN NORWAY	58
D. Hareide, H. Hodnesdal, T. Tørresen and T. Ellef Hansen Østebøvik	
THE ESEAS-RI SEA LEVEL PILOT STATION IN VILAGARCÍA DE AROUSA	61
B. Martín, B. Pérez, E. Alvarez Fanjul	
COMPARISON OF RADAR DEVICES IN GERMANY.....	65
C. J. Blasi and U. Barjenbruch	
EXPERIENCE WITH SRD TIDE GAUGES AND REASONING BEHIND CHANGE TO RADAR TIDE GAUGES	67
R. Farre	
PRESSURE GAUGE BASED GLOSS SEA LEVEL STATION AT TAKORADI HARBOUR (GHANA, WEST AFRICA): EXPERIENCES OVER A YEAR.....	69
A. Joseph, P. Mehra, J. Odammetey and N. E. Kofi	
CHILEAN SEA LEVEL NETWORK	72
J. Fierro	
GAUGES FOR TSUNAMI WARNING	75
B. Kilonsky	
ODINAFRICA TIDE GAUGE SPECIFICATION AUGUST 2005.....	76
P. Foden	
TIDETOOL – A SOFTWARE PACKAGE TO DISPLAY AND DECODE SEA LEVEL DATA TRANSMITTED OVER THE WMO GLOBAL TELECOMMUNICATIONS SYSTEM	77
L. Kong	

1. Introduction

This is the fourth in the series of IOC Manuals on Sea Level Measurement and Interpretation. It incorporates the changes in tide gauge technology and measurement techniques in the five years since the third manual was written, and includes material from the Workshop on New Technical Developments in Sea and Land Level Observing Systems (UNESCO, Paris, 14–16 October 2003). In addition, it reflects to a great extent the changes in priorities for tide gauges in a global network which have taken place in recent years. For example, it is inconceivable now that most gauges installed in the GLOSS network will be without a real-time reporting capability and a capacity to provide data of use to a tsunami warning system.

The manual includes some sections of text from the earlier editions, updated as appropriate. However, for reasons of space it does not include some other sections from the earlier versions, even though they are still valid and useful (e.g. the discussion of data quality control and filters in Volume III, see the present Appendix II). The earlier editions continue to be readily available on the web at <http://www.pol.ac.uk/psmsl/manuals/>.

In order to provide a fresh perspective, this volume has been largely written by new people. A consultant (Dr. Ian Vassie) produced a first draft. Drs. Tilo Schöne and Georg Beyerle of GFZ, Postdam, contributed the text for section 8. The first drafts were commented on and edited by the GLOSS Technical Subcommittee (Chair Dr. Begoña Pérez) and the volume was subsequently reviewed by members of the GLOSS Group of Experts and Mr David Meldrum provided additional comments on Section 5.

The following section provides a brief overview of sea level variations which may be of general interest, including a discussion of estimation of extreme levels that was missing from earlier editions. However, the volume is largely concerned with tide gauge and data communications technologies and aimed at people who work in those fields. These are rapidly developing topics, and ones in which the sharing of expertise among groups is essential. Some readers of this volume may, therefore, have different perspectives on sea level measurements. Some of these independent views are expressed in the contributions given in Appendix V. Each of these authors has expressed willingness to provide advice to others as required.

We thank everyone who contributed material for, and advice on, this volume. In particular, we thank Robert Smith of the Proudman Oceanographic Laboratory for his technical assistance and Ray C. Griffiths for editorial assistance.

Thorkild Aarup
(GLOSS Technical Secretary)

Mark Merrifield
(Chair GLOSS Group of Experts)

Begoña Pérez
(Chair GLOSS Technical Subcommittee)

Ian Vassie
(Consultant)

Philip Woodworth
(Director, Permanent Service for Mean Sea Level)

June 2006

2. The Nature of Sea Level Variations

2.1 Introduction

The study of sea level has many different facets. It is not simply the measurement of the sea level that requires technical expertise. The data must be carefully calibrated, checked and evaluated. The measurements should be tied to local benchmarks that in turn are fixed into a country's national levelling network and further fixed into the global network using modern geodetic techniques. The recorded data need to be archived, documented and protected for future studies. Only then is it of benefit as a valuable resource and can be used for studies ranging from local engineering projects to long-term global climate change.

Variations in sea level contain contributions from different physical sources that are usually distinguished by their period. Components range from surface gravity waves with periods of 1 to 20 seconds; seiches and tsunamis with periods of minutes to over an hour; tides centred around 1/2 and 1 day; meteorological effects of several days to 1 year; interannual and decadal variability; and long-term trends in the mean level caused by geological and climatological effects. The magnitudes of these components vary enormously. Surface gravity waves can have amplitudes up to 30 m. Tsunamis tend to be less than 1 m in the deep ocean but may be several metres near the coast. Tides are relatively small in the ocean but may be 10 metres near the coast. Storm surges may be of the order of a few metres in shallow seas. Within this mix one is trying to estimate long-term trends in the mean level of the order of 1 mm per year. The fact that this is possible, and has been for over 100 years, is testimony to the expertise and dedication of the engineers and scientists who are involved in sea level research.

The majority of historical sea level data were collected from float and stilling-well tide gauges with analogue charts, many of which are still in existence, but superseded by the modern trend to the digital systems described below. With digital technology it is possible to improve the accuracy and reliability of the data and make the data available to the user in real time.

In analogue form the charts were always available for re-analysis and errors could be rectified by reappraisal of the chart and re-sampling of the pen-trace, if necessary. In digital form a corresponding re-analysis is not always possible. The decision has to be made in advance as to what is a reasonable sampling (or averaging) interval. One cannot return and re-sample the data at a more frequent interval. In the past, the generally accepted sampling (or averaging) rate was 1 hour, since this allowed the study of all processes, from tides to mean sea level (IOC, 1990). Waves were, by their nature, considered a different scientific province and were filtered out of the data. More recently, the sampling frequency has been increased to 15 minutes, 6 minutes and even higher rates.

The disastrous tsunami of 26 December 2004 in the Indian Ocean made it clear that the normal tide gauge sampling would be inadequate and that it would be necessary to increase it to 1 minute or ideally to 15 seconds. This places constraints on the tide gauge technology and increases the demand on the storage and transmission requirements of a tide gauge network. There is a balance to be struck between the need to capture the essence of the data and the need to store and perhaps transmit large volumes of data.

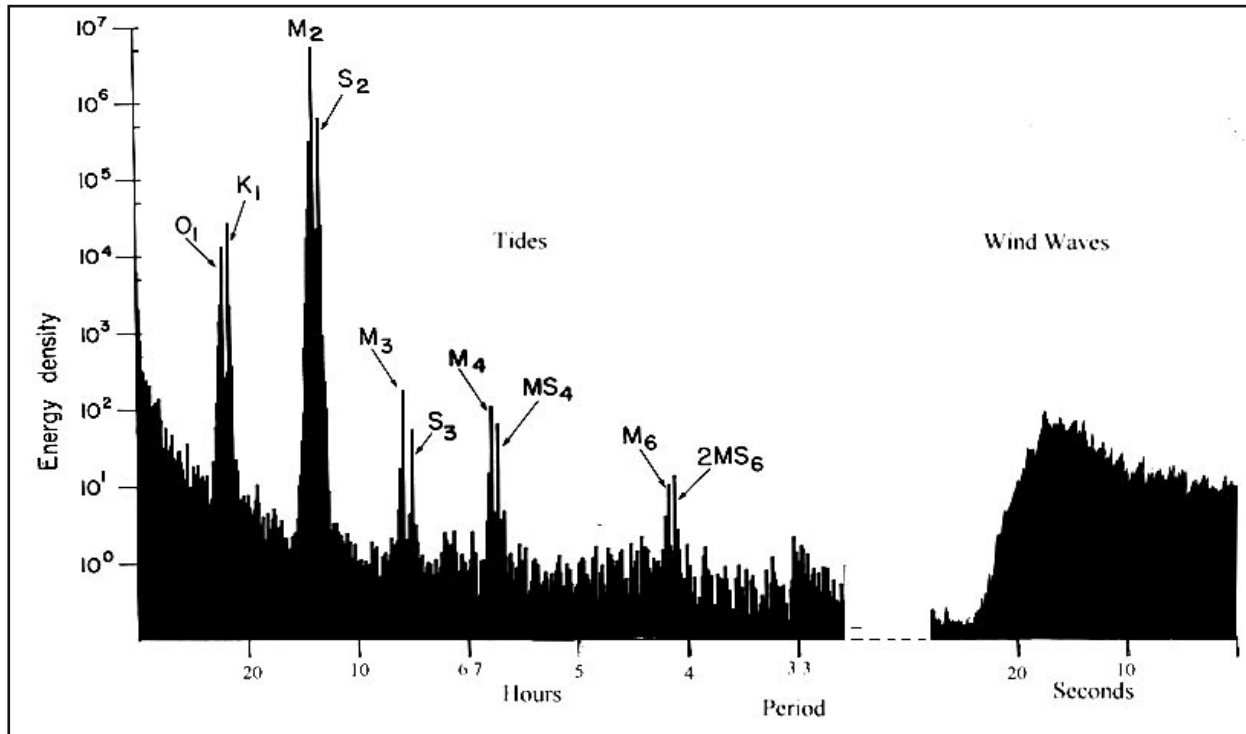

Figure 2.1 Spectrum of Sea Level Variations. The long-period variations and mean sea level changes are part of the enhanced energy at low frequencies.

A second important issue is that, historically, a tide gauge was attended continuously by a trained observer who collected ancillary tide-pole information, and height and datum corrections were appended to the chart weekly. This produced a very stable reference and of course meant that faults were quickly identified. In modern systems the datum and calibrations tend to be checked less frequently. Thus greater reliance is placed on the accuracy and stability of the measuring equipment. Fortunately, modern technological improvements have allowed this, not only through better equipment, but with two-way communication the sea level station can be interrogated and its operational characteristics adjusted as necessary.

The need for an operator to be permanently at the tide gauge has been removed. Perhaps one can speculate that it is time to withdraw all manual intervention. Certainly, with the growing requirement for real-time data, manual intervention will not always be possible. In the future, the only viable approach might be to check and authenticate the data automatically at source before transmission. It can then be passed to the end user and be placed in a form that can be entered directly into the global sea level data banks without intervention.

2.2 Surface Waves

Surface waves are probably the most noticeable variation of the sea surface to a casual observer. They have been relatively little discussed in previous editions of this manual,

as most tide gauges are designed to filter out such waves. However a brief description of their characteristics is worth including, as the design of a tide gauge relies on an understanding of their general characteristics.

Waves are characterized as wind-waves or swell. Wind-waves are generated by the effect of the wind on the local sea surface and have a relatively broad spectrum. Swell is produced when the waves propagate out of a storm area. They occupy a narrower part of the spectrum. In general, wind waves have periods from 1 to 15 seconds, and swell, from 12 to 25 seconds, although this definition is not exclusive. Outside this range of periods, wave amplitudes are small. Wave period is usually calculated via the time between successive zero up-crosses of the wave (T_z).

Wave heights are usually defined in terms of their peak-to-trough range in height, although wave amplitude is sometimes calculated as the height above a mean level. Significant wave height (H_s) is the usually quoted parameter which closely approximates the height of the highest one-third of the waves in a given period of time. Traditionally, a wave record has a duration of 20 minutes and is re-sampled every 3 hours, choices which were derived originally from the stochastic properties of storm duration. It is difficult to give an overall figure for maximum wave height, as it depends critically on location. Waves are subject to amplification, dispersion, refraction and focusing. In general, significant wave heights of several metres are common during a storm, but individual waves up to 30 metres have been measured.

Wave activity with a period of a few minutes can be caused by non-linear effects; e.g. when the waves encounter a current or a change in bottom topography. These longer-period waves occur because the height of successive waves is not uniform; they occur in groups of higher or lower waves. This leads to the popular misconception that every seventh wave is the highest. In fact, the wave groups are not of equal length but they do produce non-linear effects that have periods related to the period of the wave groups. The most significant effect of this, as far as the study of sea level is concerned, is that the wave groups produce 'set-up' of the sea level near the coast. The degree of 'set-up' depends on many factors, of which the shape of the beach is the most critical. Set-up can be of the order of a few tens of centimetres during a severe storm.

Waves have directional properties as well as a magnitude. Many early recordings were only concerned with wave height, because instruments capable of measuring direction were not available. Wave riders from this era were moored to the sea bed on a flexible coupling and contained accelerometers which were integrated twice to obtain wave height. However, modern moorings are now available which are capable of measuring pitch and roll of the surface buoy, from which directional information can be derived.

Coastal tide gauges tend not to be located optimally to measure wave conditions in the nearby deep ocean. However, they can at times provide useful information with the correct (pressure) gauge technology. Vassie et al. (2004) provide a recent description of the use of pressure tide gauges to measure swell at ocean islands.

2.3 Seiches

Seiches are periodic variations in the surface level usually set in motion by a disturbance such as a strong wind or current, a sudden change in atmospheric pressure or even a tsunami. In lakes and gulfs their period is controlled by the dimensions of the basin and their lifetime is determined by frictional effects. Typical periods are in the range of a few minutes to a few hours (between wind waves and tides), and typical amplitudes are centimetric to decimetric. They can be seen on tide gauge records from almost all regions. Seiches have largely been ignored in most sea level studies, owing to their primarily local origin, but knowledge of them is important for coastal and harbour engineering as well as for harbour operations, where small-amplitude seiches may be associated with strong currents at the entrance of the harbour. On the other hand, they can have a major effect on other sea level studies. For example, if their amplitude is large enough, and if the sampling rate of the tide gauge is insufficiently high, then their energy can be aliased into tidal and other sea level signals.

2.4 Tides

The oceans respond to the gravitational attraction of the Moon and the Sun, and the solar radiation, to produce the tides, which are normally the predominant signals in sea level records. The tides are easy to distinguish from other components of sea level variation (e.g. storm surges) because they have well defined periods, whereas other processes tend to occur at irregular intervals.

An examination of the forces causing the tides leads some way towards an understanding of their nature. This examination is usually via discussion of the Equilibrium Tide (Doodson and Warburg, 1941; Forrester, 1983; Pugh, 1987; Open University, 1989). The gravitational attraction of the Moon and Sun on the Earth produces a semi-diurnal (2 cycles per day) 'tidal bulge', which is usually oriented at an angle to the equator producing the diurnal (1 cycle per day) tidal components. The diurnal and semi-diurnal waves both have a planetary space scale. As the Earth rotates about its axis, signals containing the above periods, but usually dominated by the semi-diurnal component, should appear in the sea level record. A lunar day is slightly longer than a solar day by approximately 50 minutes, leading to lunar and solar tides of differing periods which interact over 14 days to produce the Spring-Neap cycle.

Study of the celestial motion of the Earth–Moon–Sun system leads to a more complex form of the tidal potential (or Equilibrium Tide) in which the main constituents are modulated at periods of 1 month, 1 year, 8.85 years, 18.61 years and 21,000 years. The effect of the modulation is to split the tides into additional constituents but with periods close to 1 and 2 cycles per day. This grouping is termed 'tidal species'.

The tidal potential so far discussed explains only the diurnal and semi-diurnal species of the tide, but can be extended to include ter-diurnal (third of a day period) tides and tides of even shorter period. A power spectrum of a tidal record clearly shows that higher-order species do exist, except sometimes when measurements are made at an oceanic location. These 'compound tides' are primarily generated by the main tidal components in shallow water as they encounter frictional forces. They have periods of 2, 4 and 6 cycles per day (and even 12 cpd in very shallow areas), with each species demonstrating separate tidal characteristics.

The tidal regime varies enormously in different parts of the world. In most regions the tide is dominated by semi-diurnal components, reflecting the importance of the main semi-diurnal terms in the Equilibrium Tide. However, there are many areas where the tides are predominantly diurnal (e.g. Persian Gulf), and some where the regime is 'mixed' (i.e. the diurnal and semi-diurnal components have a comparable magnitude). Examples of these various regimes are shown in Figure 2.2.

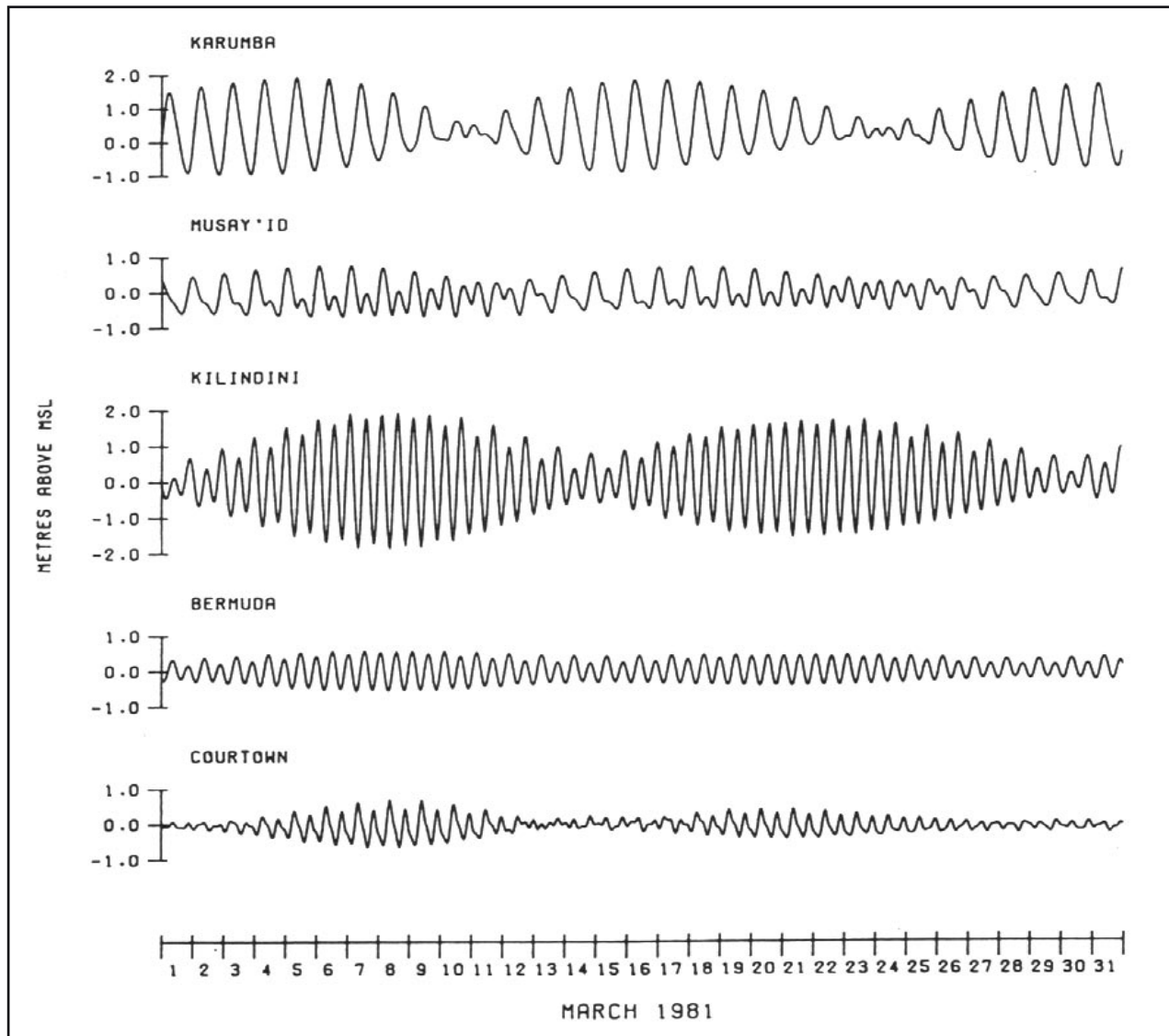

Figure 2.2 Tidal characteristics at five stations, showing different regimes: diurnal, mixed, semi-diurnal with strong spring-neap modulation in the Indian Ocean, semi-diurnal with smaller amplitudes at a N. Atlantic site, and shallow water distortions.

While the temporal characteristics of the tide in the real ocean are similar to those of tidal potential (Equilibrium Tide), their spatial characteristics are very different. This difference is caused by the dynamical response of the ocean basins, causing the tides to propagate as progressive waves and to generate standing waves in some areas. Tides in the deep ocean have amplitudes of typically 1 m or less, considerably lower than the amplitudes on continental shelves where local resonances can produce large amplitudes. In all oceans (deep oceans as well as the enclosed sea areas of continental shelves) there are regions of no tide, called amphidromic points, which are a consequence of the standing waves.

Tide gauges, such as those described in this manual, remain the primary source of tidal knowledge in coastal regions, although new techniques are under continuous development (section 8). The tides of the deep ocean

can also now be well measured, with the use of bottom pressure recorders (Cartwright et al., 1980; Filloux, 1980; Spencer and Vassie, 1997), and more recently by means of altimeter satellites (Shum et al., 1997).

2.4.1 Tidal Analysis

The model that has been derived for the Equilibrium Tide is not completely without use, as it does provide the knowledge that the tide is composed of a finite number of constituents of calculable frequency. It also provides a measure of their relative amplitudes so that we have an idea which constituents are important in the real tide.

The analysis consists in reducing a set of measurements, which amounts to 8,760 hourly values in a normal year, to a manageable set of parameters which completely specify the tidal component of the record. The tides can then be removed to reveal the remaining

components of the sea level variations (e.g. storm surges, tsunami) and the long-term trend.

Many organizations have developed their own method of tidal analysis. Apart from the Response Method (Munk and Cartwright, 1966), these methods generally fit, in some optimal way, a set of harmonic constituents to the data. This can be done in several different ways. The Admiralty Semi-Graphic Method and those of Doodson (1928) were designed for hand calculations. Most modern techniques (Murray, 1963; Foreman, 1997) rely on the ability of the computer to solve large sets of simultaneous equations. Many have been converted to 'user friendly' packages and are available from the following website: <http://www.pol.ac.uk/psmsl/training/analysis.html>.

2.5 Storm Surges

The exchange of energy between the atmosphere and the ocean is one of the most important topics in geophysics. Storm surges are among the more spectacular examples of energy transfer in which the energy contained in winds and time-dependent changes in air pressure are absorbed by the sea to produce strong currents and high sea levels. In the open sea these currents decay by the action of dissipative forces. Where the current is impeded by the presence of a continental shelf or other discontinuity in depth, or by a coastline, more of the kinetic energy of the sea tends to be converted into potential energy. Abnormal elevations of sea level may then occur, with disastrous results if the coast is low-lying.

Physically, the atmosphere acts on the sea in two distinctly different ways. The first is the 'Inverse Barometer (IB) Effect' wherein a 1-hPa (mbar) increase of atmospheric pressure decreases sea level by 1 centimetre. (Dynamical effects can complicate this simple IB description at short time-scales.) The second is due to the drag (or 'stress') of the wind on the sea surface, which is proportional (to a first approximation) to the square of the wind speed. This force sets up sea level gradients which are proportional to wind stress divided by water depth, and which result in the storm surges in shallow water regions. The dynamics of surges in shallow water result in flow being in the direction of the wind, differing from a deeper water situation in which the transport is at right angles to the wind (to the right in the northern hemisphere).

Recordings of sea level at any coastal station contain some evidence of the influence of winds and pressure, but some areas are particularly susceptible to large surges. The Baltic, being virtually an enclosed sea and subject on occasion to severe gales, experiences large surges. In 1924 St. Petersburg (Leningrad) was flooded by a surge 4 m high. The North Sea, with its southern extremity almost closed, responds readily to northerly winds; the vulnerable coastlines of the German Bight,

eastern England and more particularly the Low Countries have repeatedly been inundated by great surges. The storm surge of 1953 resulted in many deaths in The Netherlands and England. The Hamburg disaster of 1962 was more localized, mainly affecting the German Bight and the River Elbe, where the surge reached more than 3 m in height.

Hurricanes travelling towards the Atlantic seaboard of the United States are no less effective in generating destructive surges. The Japanese islands are also subject to typhoon surges. Events on this scale demand as complete an understanding of the phenomena as possible so that they may be forecast (using forecast meteorological information) and their consequences mitigated. After the immediate danger of flooding, the subsequent dislocation of normal services, such as water supplies and sewerage, gives rise to serious dangers. Also, once flooded by sea water, previously fertile lands are unsuitable for growing crops for several years because of the saline deposit which remains after the floods have receded.

For scientific analysis and for systems designed for surge prediction, it is usual to distinguish between tropical and extra-tropical surges.

Tropical surges are generated by tropical storms that are small and very intense. These storms are generated at sea, from where they move in an irregular way until they meet the coast. Here they produce exceptionally large flood levels over a region of perhaps 10–50 km of coastline. Tropical storms are difficult to monitor offshore and their effects on a particular stretch of coastline cannot be estimated from the statistics of observed floods because such storms are relatively rare events in any particular region. A combination of numerical and statistical models may be used to estimate the maximum flood levels, but their exact location depends on the track of each individual storm.

Extra-tropical surges are generated by storms which extend over several hundred kilometres and which are generally slow moving. They affect large areas of coast over periods that may extend to several days. At their centre is a region of low atmospheric pressure. They are more amenable to study by hydrodynamic modelling taking into account the distribution of atmospheric pressure and wind fields, sea bed bathymetry, the coastal topography and the effects of the Earth's rotation.

A tide gauge network by which the storm surge can be monitored is of key importance in providing data to enhance the performance of operational hydrodynamic tide–surge models used in flood warning. Data can be used in the verification of the models and for data assimilation into them (Flather, 2000; Alvarez Fanjul, 2001). Such a network clearly has to be capable of remote telemetry on a near-real-time basis.

2.6 Tsunamis

A tsunami is a wave train generated by a vertical displacement of the water column. Earthquakes, landslides, volcanic eruptions, explosions, and even the impact of cosmic bodies, such as meteorites, can generate tsunamis. Where they impact a coastline, they can cause severe property damage and loss of life. Tsunamis may have wavelengths in excess of 100 km and periods of minutes to over an hour, depending on the generation mechanism. As a result of its long wavelength compared to the water depth, a tsunami behaves like a shallow-water wave and propagates at a speed that is equal to the square root of the product of the acceleration of gravity (9.8 m.s^{-2}) and the water depth. In a typical ocean depth of 4,000 m, a tsunami travels at about 200 m.s^{-1} , or over 700 km.hr^{-1} . Because the rate at which a wave loses its energy is inversely related to its wavelength, tsunamis not only propagate at high speeds, they can also travel great distances without loss of energy (Figure 2.3). Tsunamis are only about a metre high, at the most, in the open ocean. However, where they impact the coast, amplitudes are significantly higher and can be as large as 10 m (30 m in extreme cases). Wave refraction, caused by segments of the wave moving at different speeds as the water depth varies, can cause extreme amplification in localized areas.

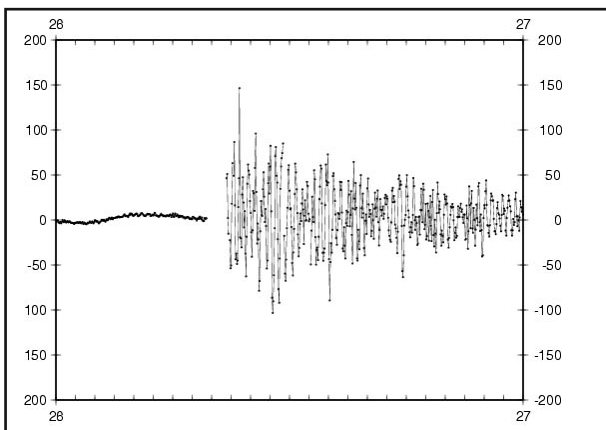

Figure 2.3 The 26 December 2004 Sumatra tsunami signal at a distant tide gauge (Port Louis, Mauritius) with an amplitude over 1 m.

The ability to warn of the approach of a tsunami depends on a variety of measurements (especially seismic data), but also on a network of tide gauges to monitor the progress of the wave and thereby forecast the time of arrival at a distant coast and the likely affected areas. Because the propagation speed of the waves is large, it is essential to have real-time data transmission without any significant time delay. Decision-making and mitigation procedures have to be considered before warnings are issued to the relevant authorities.

2.7 Mean Sea Level and Trends

The determination of mean sea level (MSL) and its long-term trend is probably the most exacting component of a tide gauge data set. Whereas the accuracy of an instrument in determining the properties of the tides or a storm surge need only be about 1 cm, the long-term trend in sea level has a magnitude of around 1 mm per year. Hence precise measurement not only relies on the accuracy of the instrument but also on its long-term stability. This in turn implies an ability to maintain the datum of a tide gauge within a local levelling network. The levelling between, and geocentric fixing of, tide gauge benchmarks, is dealt with in section 4.

The data from the existing global network of tide gauges clearly shows a rise in sea level over the last century. Their data are fundamental in studies of climate change, and especially as an aid in the development of atmosphere–ocean general circulation models that have a capability to predict future sea level change. The mean value is extracted from the observed data by the application of numerical filters discussed in Volume 1 of the IOC Manual on Sea Level Measurement and Interpretation. Monthly and annual mean sea level series are collected and published by the Permanent Service for Mean Sea Level (PSMSL), together with details of gauge location, and definitions of the datums to which the measurements are referred. Data are held for over 2,000 stations, of which 112 have data from before 1900. The longest record held is from Brest, France, which begins in 1806. The physical location of gauges on the network is not ideal: the vast majority of gauges operate in the northern hemisphere and careful analysis is necessary to avoid bias in the interpretation of their data. There is a continuing need for more data from the southern hemisphere, and from oceanic islands.

The change in mean sea level relative to a fixed point on land is a measure of the difference between the vertical movements of the sea's surface and of the land itself. Long-term changes of measured sea level are termed 'secular' changes. Global changes in the mean sea level are called 'eustatic' changes. Vertical land movements of regional extent are called eperiogenic movements. Examples of such long-term changes can be obtained from the PSMSL website. Study of the records will show that there are many similarities between stations which can be considered 'nearby' relative to ocean and geological space-scales. The close agreement between stations using different kinds of instruments shows that the oceanographic variability is much greater than the errors in the measurements.

2.8 Estimation of Extreme Sea Levels

2.8.1 Introduction

The aim of this section is to summarize the key methods which can be used for the estimation of extreme

sea levels. It begins with the classical method of Annual Extremes, which first appeared in the early 1960s and continued to be developed for some time thereafter. Following this, the Joint Probability Method, which was developed in the late 1970s, is considered. This makes more efficient use of data by incorporating our extensive knowledge of the tides and storm surges, which are the two main components of sea level, as a part of the estimation procedure.

More recent work on the Annual Exceedance Method is discussed, followed by a revision of the Joint Probability Method to correct its deficiencies in areas where the sea level is dominated by the meteorological surge component. Finally, very recent work on the spatial estimation of extremes is mentioned. References are given at each stage so that the reader can examine any of the methods in greater depth. Although extreme high sea levels are considered, results for extreme low sea levels can be obtained in an analogous way.

2.8.2 The Annual Maximum Method (AMM)

This is the classical general method of analysis of extremes having been applied to sea level estimation since 1963 (Lennon, 1963; Suthons, 1963). It is based on a result from probabilistic extreme value theory which states: if X_1, \dots, X_n is a sequence of independent and identically distributed random variables, then $\max(X_1, \dots, X_n)$, suitably linearly normalized, converges as $n \rightarrow \infty$, to a random variable with a distribution function which is one of the so called extreme-value distributions. The general case is known as the Generalized Extreme Value (GEV) distribution. An important special case is the Gumbel distribution.

The Annual Maximum Method takes the GEV to be the distribution function of the maximum sea level in a year. Therefore, for a place of interest, the annual maximum for each year is extracted from hourly observations and is used as data to estimate the parameters of the distribution that they follow. From the estimated distribution one can obtain the sea level corresponding to a chosen 'Return Period'. In practice, return periods of 50, 100 and 1,000 years are common. The basic method assumes that there is no trend in the data, but it can be extended to deal with those cases where a trend is present.

A recent extension of the annual maximum method involves using probabilistic extreme value theory to obtain the asymptotic joint distribution of a fixed number (r) of the largest independent extreme values, for example the five largest in each year. Essentially the approach is the same as above except that more relevant data are included in the analysis thereby improving the estimation. Care must be taken to ensure that the number of annual maxima ' r ' is not excessive, such that the lower extremes fall outside the tail of the extreme value distribution.

This method of estimating sea level extremes is highly inefficient in its use of data, since it extracts very few values from each yearly record. This is particularly important when the sea level record is short, since it yields return level estimates with unacceptably large standard errors. In addition, it makes no use of our knowledge of the sea level and storm surge processes. However, the advantage of annual maxima methods is that they do not require knowledge of tide-surge interaction which can sometimes be a significant feature of the data. Consequently the methods are relatively straightforward to apply.

2.8.3 The Joint Probabilities Method (JPM)

This method of analysis was introduced to exploit our knowledge of the tide in short data sets to which the annual maxima method could not be applied (Pugh and Vassie, 1979). At any time, the observed sea level, after averaging out surface waves, has three components: mean sea level, tidal level and meteorologically induced sea level. The latter is usually referred to as a storm surge. Using standard methods, the first two of these components can be removed from the sea level sequence leaving the surge sequence, which is just the time-series of non-tidal residuals. For simplicity these are assumed to be stationary. Because the tidal sequence is deterministic, the probability distribution for all tidal levels can be generated from tidal predictions. This distribution can be accurately approximated using 18.6 years of predictions.

The probability distribution of hourly sea levels can be obtained either directly using an empirical estimate or by combining the tidal and surge probability density functions (*pdf*). The latter is preferable, as it smoothes and extrapolates the former. However the nature of the combination of the *pdf*s depends on whether there is dependence between the tide and surge sequences. Initially, consider the case in which they are independent.

By combining the *pdf*s of tide and surge, the distribution function of hourly (instantaneous) sea levels is obtained. From this, the distribution function of the annual maxima is required. If hourly values were independent, which is approximately the case where the tide dominates the regime, then this is straightforward.

The method has been widely applied. It makes better use of the data and of our extensive knowledge of the tides, and accounts for surges that could have occurred on high tide but by chance did not. Most successful applications have been to sites which have several years of hourly records (>10 years) and where the site is tidally dominant, i.e. where the tidal range is large in comparison to the surge amplitude. Least successful applications have been to sites with both short lengths of data and where the site is surge dominant.

2.8.4 The Revised Joint Probabilities Method (RJPM)

Particular emphasis was given to two principal improvements that make the revised method more widely applicable than the original joint probabilities method (Tawn et al., 1989). It was principally directed at sites where the storm surge was responsible for a respectable proportion of the sea level and to improve the estimation procedure for sites where less than 10 years of data were available.

The first issue was that of converting the hourly distribution into annual return periods. It is clear that each hourly value of sea level is not independent of its predecessor or successor. Of the 8,760 hourly values in a year, it is necessary to determine the effective number of independent observations per year. This was done through an Extremal Index which is derived from the mean overtopping time of a level for each independent storm which exceeds that level. In fact the Extremal Index can be shown to be a constant in the region of the extremes. Because large values tend to cluster as storms, it should be expected that the Extremal Index >1 ; for example, in the North Sea, it is 1.4. This effectively reduces the number of independent observations from 8,760 to $8,760/1.4$. If the site is tidally dominant then the Extremal Index is considerably smaller than if the site is surge dominant. The immediate advantages of this modification are: firstly, that no assumption about the local dependence of the process is required; secondly, that the conversion from the hourly distribution to annual maxima is invariant to sampling frequency.

The second modification enabled probabilities for levels beyond the existing range of the surge data to be obtained, in addition to providing smoothing for the tail of the empirical distribution. The method is based on the idea of using a fixed number of independent extreme surge values from each year to estimate probabilities of extreme surges. The procedure involves two important steps. Firstly, the identification of independent extreme surges. Secondly, the selection of a suitable number of independent extreme surges from each year of data, perhaps five per year. Using these surge data, estimates can be made of the parameters of the distribution of the annual maximum surge (Smith, 1986).

Using the ideas for extremes of dependent sequences, this can be related to the distribution function of hourly surge levels, and then the empirical surge density function can be replaced by the adjusted density. Using the adjusted density function, the convolution can be performed to combine the tidal and surge distributions to obtain the hourly sea level distribution and hence the return periods can be calculated for different levels.

When interaction is present, the level of the tide affects the distribution of the surge. In particular, the tail of the surge *pdf* depends on the corresponding tidal level. Thus the convolution of tide and surge can be adapted so that the surge parameters are functions of tidal level. This formulation also enables statistical tests of independence to be performed.

2.8.5 The Exceedance Probability Method (EPM)

An alternative method of obtaining extreme sea level estimates from short data sets is called the exceedance probability method (EPM) (Middleton et al., 1986; Hamon et al., 1989). The EPM, like the RJPM, involves combining the tide and surge distributions and accounting for dependence in the sea level sequence. The approach differs in the way that it handles extreme surges. The EPM uses results for continuous time processes and makes assumptions about the joint distribution of the surge and its derivative. Improvement is achieved by allowing flexibility in the surge tail through the use of a contaminated normal distribution.

2.8.6 Spatial Estimation of Extremes

Extreme sea levels along a coastline are typically generated by the same physical mechanisms, so the parameters that describe the distribution are likely to be spatially coherent. Models that describe the separate constituents of the sea level are best suited to exploiting this spatial coherence, as the individual parameters should change smoothly along a coastline.

The joint distribution of annual maxima over several data sites can be modelled using a multivariate extreme-value distribution (Tawn, 1992). Changes in each of the parameters of the distribution, over sites, can be modelled to be consistent with the properties of the underlying generating process identified from the RJPM. The main advantage of the spatial method is that it can utilize data sites with extensive sea level records and augment these with data from sites with shorter records of a few years.

3. Instruments for the Measurement of Sea Level

3.1 Introduction

This section contains information on the types of instrument that are presently available for the measurement of sea level. The reason that so many different technologies have evolved is connected with the difficulty of measuring a fluid that is in constant motion due to the processes discussed in section 2. In general, sea level measurements are not concerned with the measurement of surface gravity waves which must be filtered out of the system. Waves can be appreciable in amplitude and can cause problems for most forms of tide gauge technology. Therefore, their potential effects on a 'sea level' measurement must always be kept in mind. Another factor that needs to be considered is that the properties of sea water (salinity, temperature and hence density) may change on a regular or irregular basis. How this affects an instrument depends much on the technology used to acquire the observations. These are discussed along with the merits of each tide gauge.

There are fundamentally four types of measuring technology in common use:

- A stilling well and float: in which the filtering of the waves is done through the mechanical design of the well.
- Pressure systems: in which sub-surface pressure is monitored and converted to height based on knowledge of the water density and local acceleration due to gravity. Such systems have additional specific application to ocean circulation studies in which pressure differences are more relevant than height differences.
- Acoustic systems: in which the transit time of a

sonic pulse is used to compute distance to the sea surface.

- Radar systems: similar to acoustic transmission, but using radar frequencies.

Within each of these four types, different technologies have been employed, leading to different designs.

In addition, there are direct measuring devices based on resistance or capacitance rods, but these have found less widespread use because of their lack of robustness in hostile regions. Recent advances in technologies, such as Global Positioning System (GPS) reflection methods, have led to other elaborate ways of measuring sea level which might be important in the future.

At the present time, many of the above systems are undergoing tests and inter-comparisons by agencies worldwide (IOC, 2004). It would appear that most systems for measuring sea level have a precision approaching 1 cm, given sufficient care and attention. This value is adequate for the measurement of most of the hydrodynamic processes discussed in section 2. However, this precision does not necessarily imply an accuracy for adequate measurement of the mean level. The determination of the mean level depends as much on the long-term stability of the measuring system.

There are practical constraints that govern the choice of an instrument for a particular application. These include cost, degree of difficulty of installation, ease of maintenance and repair, support facilities etc. For example, the installation of a highly complex electronic instrument with sophisticated software control would be unwise without technical support staff who possess

the ability to maintain its operation. Another important consideration in the choice of an instrument is the site at which it is to be located. This is discussed in the next section.

Traditionally, permanent sea level stations around the world have been mainly devoted to tide and mean sea level applications, and this has been the main objective of GLOSS. This implies that not only wind waves are filtered out from the records by mechanical or mathematical procedures, but any oscillation between wind waves and tides (e.g. seiches, tsunamis etc.) has not been considered a priority, and in fact not properly monitored, owing to the standard sampling time of more than 5–6 minutes. If this range of the spectrum should be covered from now on, it would be necessary to consider this when choosing a new instrument and designing the sea level stations.

3.1.1 The Choice of a Tide Gauge Site

In many cases, the site for a tide gauge may be specified (e.g. it has to be located in a port area). However, in many instances, the choice of site will not be clear and can only be made by judging which of the constraints listed below are more significant and which should be given greater emphasis. This emphasis may depend on, for example, whether the gauge is intended for oceanographic research, in which case one clearly requires it to be located with maximum exposure to the open ocean, and not situated in a river. Most GLOSS Core Network sites have been selected with this aspect in mind. For local programmes, where the process to be studied may be coastal erosion or storm surge activity, then clearly the gauge will have to be situated optimally for that purpose. In most cases, some of the following constraints are still valid:

- The installation must be capable of withstanding the worst environmental conditions (winter ice, storms etc.) likely to be encountered. This is clearly an issue relevant to the type of instrument and to its intended position. Positions exposed to environmental extremes should clearly be avoided to enable the eventual accumulation of a long time-series of data.
- The ground on which the installation is to be erected should be 'stable' as far as possible, not being liable to subsidence because of underground workings or land subsidence (e.g. due to the area being reclaimed land). It must also not be liable to slippage in the event of heavy prolonged rain (i.e. the area must be adequately drained) or being eroded by river or sea action. An installation on solid rock is the ideal.
- River estuaries should, if possible, be avoided. Estuarine river water can mix with sea water to varying extents during a tidal cycle and at different times of the year, resulting in fluctuations in

water density. This may have important impacts on float gauge measurements in stilling wells because of 'layering' of water drawn into the well at different times causing a difference in density inside and outside the well. It will also impact on pressure measurements, as the density assumed for the conversion of pressure to sea level will not be constant. Currents associated with river flow can also cause drawdown in stilling wells and in the stilling tubes of acoustic gauges. Following heavy rain-storms, debris floating down-river could damage a gauge.

- Areas where impounding (isolation from the open sea) can occur at extreme low-tide levels should be avoided. Similarly, sandbars slightly below the surface between the site and the open sea can result in uncharacteristic levels being measured. Monitoring across long shallow sloping beaches should also be avoided for the same reasons.
- Sharp headlands and sounds should be avoided, since these are places where high tidal currents occur which tend to result in unrepresentative tidal constants and in a drop of MSL (Pugh, 1987).
- Proximity to outfalls can result in turbulence, currents, dilution and deposits, and should be avoided.
- Places where shipping passes or moors close to the proposed site, since there will be a risk of collision and propeller turbulence causing silt movement; a study should be made of this possible factor.
- Places where construction work in the area at some future time may affect the tidal regime at the site (e.g. by construction of new quays or breakwaters); investigations should be made to determine whether there is a possibility of this occurring. This might necessitate the relocation of the tide gauge, thus interrupting the sea level time-series. This is something very difficult to avoid in some harbours.
- A site should have continuous mains electrical power (or adequate storage batteries/solar panels or generator supply) and telephone or satellite access for transmission of data to an analysis centre.
- There must be adequate access to the site for installation and maintenance and the site must be secure from vandalism or theft.
- The area of the site must be capable of containing the benchmarks required for geodetic control of the sea level data. In particular, it must have good TGBM and GPSBM marks, which must also be secure from accidental damage.
- If stilling well or acoustic gauges are to be installed, then the stilling well or acoustic tube must be tall enough to record the highest sea levels. This may require permission from port authorities if, for example, the installation is on a busy quayside.
- The water depth must extend at least two metres beneath Lowest Astronomical Tide (LAT) for the successful operation of a stilling well. The outlet of the stilling well should be clear of the sea bed and

be set deep enough to allow the float to operate about one metre below LAT.

Finally, it is clear that tide gauge datum control is an essential issue for any installation. Consequently, even if the station is equipped with the most modern equipment, it is common sense to provide confirmation of the datum from time to time by means of an inexpensive tide 'pole' or 'staff' to guard against gross errors in the datum.

3.2 The Stilling Well

A stilling well gauge is probably the most common of all sea level recording systems on a worldwide basis. These gauges were at one time employed at every port installation and were the primary technology by which sea level records were compiled. Recent stilling well installations are less common, since they require a considerable amount of costly engineering work, so that they have often been superseded by one of the other technologies discussed below. In some circumstances it may not be possible to install a well, e.g. on a shelving beach, and other methods have to be adopted.

The function of a well is to filter out, 'to still', the wave activity, so that the tides and longer-period processes

can be recorded accurately. It is most commonly associated with having a float gauge in the well driving a pen and chart recorder or, in more recent years, a shaft encoder such that the readings of sea level height can be digitized automatically. It is not uncommon for other types of instrument, e.g. a pressure sensor, to also be placed in the well.

The well itself is a vertical tube about 1 m in diameter constructed of concrete, coated steel or plastic, with a hole or, less frequently, a pipe connection to the sea. The ratio of the hole diameter or pipe length and diameter to that of the well gives it the characteristics of a low pass filter (Noye, 1974a, b, c). In other words, it acts as a mechanical filter. Care has to be exercised in trying to measure processes such as tsunami waves, as the frequency response is not 100% for periods ≤ 4 hours. The stilling well suffers from amplitude attenuation and a phase lag at shorter periods which are critically dependent on the design of the well and sometimes difficult to change.

The characteristics, installation and use of a stilling well were covered in substantial detail in Volume 1 of the Manual of Sea-Level Measurement and Interpretation (IOC, 1985). The reader is advised to refer to that publication, and for additional information on the characteristics of the stilling well, to Noye (1974). Lennon (1971) dealt in detail with errors that arise in the operation of such a system.

A schematic diagram of a float gauge in a stilling well is shown in Figure 3.1. The float wheel is shown driving a pen recorder, but the same pulley could equally drive a digital shaft encoder or a potentiometer, which can then be recorded by a local data logger or interfaced to a telemetry system. The well is shown with a conical inlet at its base, since this is the most common configuration and is to some extent self-cleaning. Many other configurations of the inlet are acceptable, and although the conical orifice does restrict the inflow relative to the outflow, this does not appear to have a significant effect on the records even in the presence of waves.

3.2.1 Datum Switches

In common with all other types of sea level recording systems, the setting and control of datums is of crucial importance. This topic is dealt with in section 4. Stilling well tide gauge installations were, at one time, attended on a continuous basis. Under these circumstances visual comparisons were made with a fixed tide gauge staff on a regular basis and appropriate time and datum corrections were applied to the data. Without this, alternative means of fixing the datum have to be found. One alternative is to site a level switching device as part of the installation at approximately mean sea level. The switch indicates the instant at which the sea

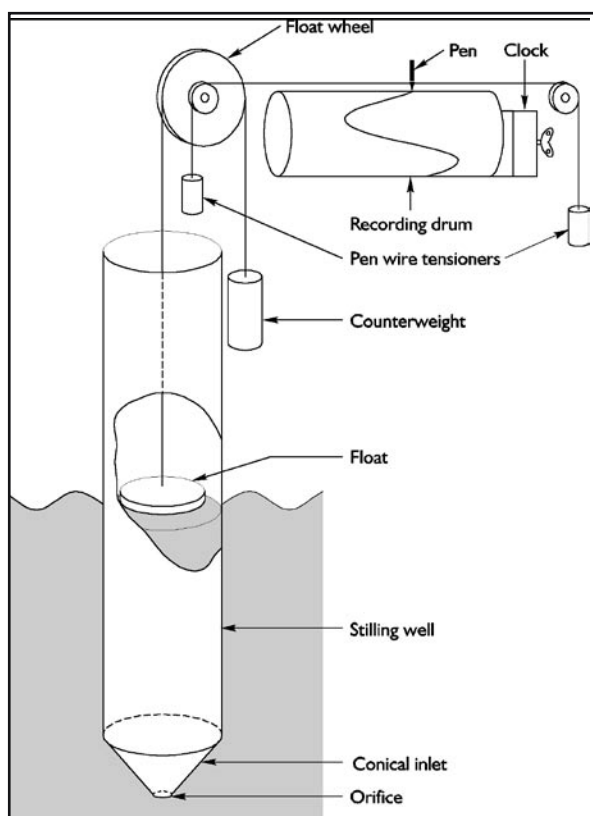

Figure 3.1 Stilling well tide gauge.

crosses the level of the switch, a level that is known relative to all other datums of the tide gauge. Ideally the switch, which can be mechanical, optical or acoustic, should be sited outside the well in its own mini-stilling well. The switch provides a correction for any datum shift that previously would have been manually recorded by an operator. Although the switch will not work correctly under all conditions, e.g. when high waves or a seiche is present, there will usually be sufficient days of calm to obtain an accurate datum check.

3.3 Pressure Gauges

Instruments that measure subsurface pressure instead of sea level directly have found widespread use. A knowledge of seawater density and gravitational acceleration is required to make the conversion from pressure to sea level, but in spite of this, the instruments have many practical advantages as sea level recorders. The most commonly used types are the pneumatic bubbler gauges and pressure sensor gauges in which sensors are mounted directly in the sea. The two types have much in common and a choice of which type is suitable is usually based on practical considerations at a proposed site.

3.3.1 Pneumatic Bubbler Gauges

The pneumatic bubbler tide gauge has been successfully used worldwide for several decades. It replaced many of the float-operated harbour gauges as the pri-

mary standard for sea level measurement in countries such as the United States and the United Kingdom, although in the USA they have since been superseded by acoustic gauges (section 3.4). The UK still operates its National Tide Gauge Network (44 stations) based on this technology. It has been shown to be robust, both in terms of accuracy and datum stability. It has demonstrated its value in situations where there are no vertical structures on which to attach the equipment, e.g. on coral atolls (Pugh, 1978), as the part of the equipment installed in the sea and on land can be several hundred metres apart, which is not the case with many other types of instrument.

Figure 3.2 shows the basic essentials of a bubbler system. Air is passed at a metered rate along a small-bore tube to a pressure point fixed underwater well below the lowest expected sea level. The pressure point normally takes the form of a short vertical cylinder with a closed top face and open at the bottom. A small 'bleed hole' is drilled about half way down its length and metered air is entered through a connection on the top surface. As air from the tube enters the pressure point it becomes compressed and pushes the water down inside the chamber until the level of the bleed hole is reached at which time the air bubbles out through the hole and back to the surface. Provided that the rate of air flow is low and the air supply tube is not unduly long, the pressure of air in the system will equal that of the pressure due to the depth of the sea water above the bleed hole coupled with atmospheric pressure. A pressure-recording

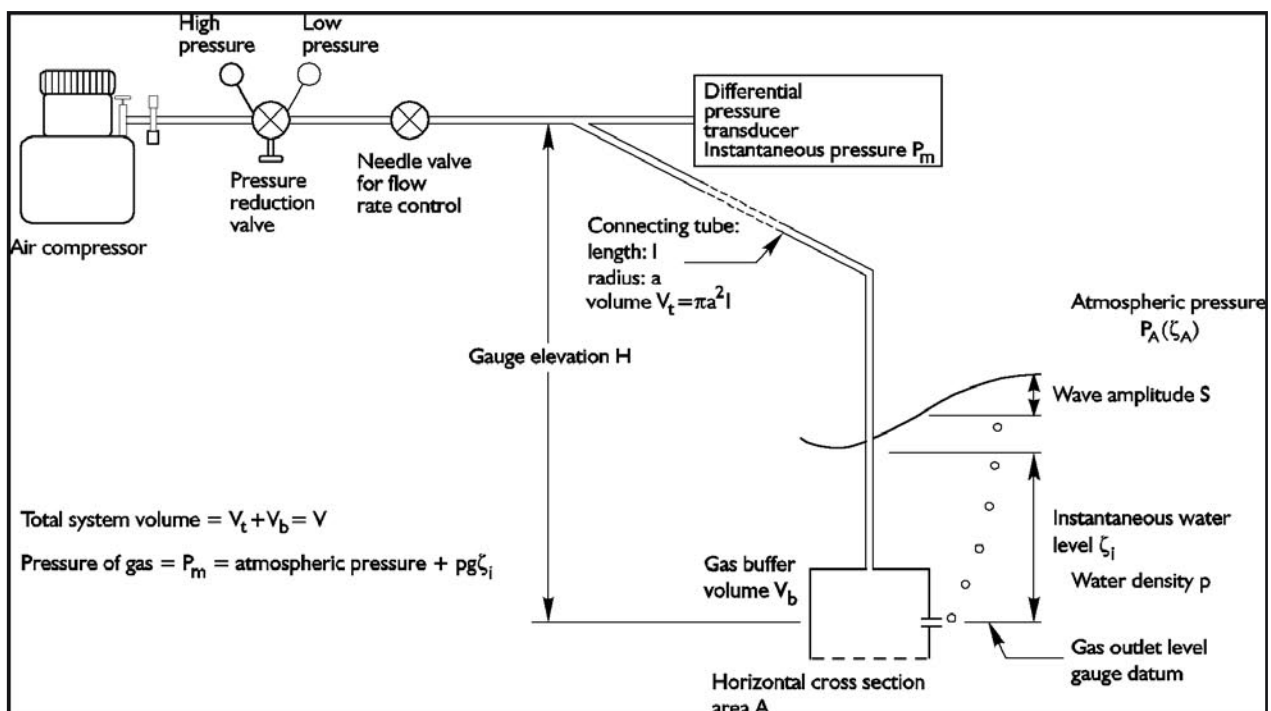

Figure 3.2 Bubbler pressure gauge.

instrument connected into this supply tube at the landward end records the changes in water level as changing pressures, according to the law:

$$h = (p - p_a) / (\rho g)$$

where h = height of sea level above the bleed hole
 p = measured pressure
 p_a = atmospheric pressure
 ρ = seawater density
 g = gravitational acceleration

Most pneumatic instruments use a pressure sensor as part of the recording equipment to monitor the changes in pressure and hence sea level. It is common to use a sensor operating in the differential mode, sensors being so constructed that the system pressure is opposed by atmospheric pressure. Hence, the resultant pressure experienced by the sensor becomes $(p - p_a)$, making the measured pressure directly proportional to the required sea level.

A knowledge of the seawater density (ρ) is important. This is normally obtained from separate water sampling, and, where the water is well mixed, can be considered constant. In estuarine locations, the density may change during a tidal cycle or seasonally, and density corrections will have to be included in the data processing.

Several other effects on the measured pressure have to be considered. These include a 'static' effect, which is a function of the height of the gauge above sea level, and a 'dynamic' effect, which results from the dynamics of gas flow. The latter can be calculated in terms of tube length and radius and the minimum air-flow consistent with preventing water from entering the system (Pugh, 1972). The effect of waves on the system is to introduce a positive bias during storm conditions (i.e. sea level is measured too high). These effects can perturb the sea level measurements at the sub-centimetre level during average conditions, but measurements may be incorrect by several centimetres under extreme waves.

In common with all pressure measuring systems, there is a need to establish a datum for the observed time series. This can be achieved in several ways: (a) from a knowledge of the exact depth of the pressure point bleed hole during installation, combined with accurate calibration of the pressure transducer; (b) using datum level switches similar to those described above for stilling wells which trigger at a known sea level; (c) by having a parallel system (called a 'B' gauge; section 3.3.4) with a second and more accessible pressure point fixed near mean sea level. Comparison of the differences between the two bubbling systems when both are submerged gives an accurate measure of the datum; method 'c' is the most accurate.

Air is normally supplied to a bubbler from a compressor to afford continuous operation of the installation. In the event of electrical supply failure, a reserve air capacity capable of sustaining the system for at least several days is necessary. For sustained operation under fault conditions, an alternative low power backup system in the form of a pressure transducer mounted directly in the sea is necessary. Transducers, compressors, data loggers etc. can be purchased from the major gauge manufacturers with ready-to-go packages. An all-bubbler system has an advantage that most components are underwater, and that all components are both robust and, if damaged, relatively inexpensive to replace.

3.3.2 Pressure Sensor Gauges

Pressure sensors can be fixed directly in the sea to monitor sub-surface pressure in a similar fashion to the bubbler gauge. The sensor is connected by a cable that carries power and signal lines to an onshore control and logging unit. In the sea, the active sensor is usually contained within a copper or titanium housing with the cable entering through a watertight gland. Material used for the housing is chosen to limit marine growth. The assembly is contained in an outer protective tube to provide a stable fixation to a sea wall or rock outcrop. Where this is not possible, the pressure sensor may be placed securely on the sea bed, but this method has disadvantages, as deployment and maintenance usually require a diving team.

Pressure-based instruments can be operated from batteries for periods of a year or more, as they consume a very small amount of power. This can be advantageous even where electrical supplies are available but subject to long periods of failure. Therefore, they have been used extensively in remote areas, such as oceanic islands, where access is limited. In polar regions, they offer the best alternative if the area is ice covered or if the gauge is to be left unattended for long periods. The main disadvantage is the lack of a fixed datum level, which has to be found by alternative means.

Pressure sensors are available in two varieties that provide either an absolute or differential signal. If an absolute transducer is employed, the sensor provides a measurement of the total pressure including sea level and atmosphere. Therefore, a separate barometer is required usually in the form of an identical transducer open to the atmosphere. Both sensors are synchronized to the same clock so they can readily be subtracted to yield sea level (with subsequent correction for density and acceleration due to gravity). Differential pressure transducers have a vented cable in which the reference side of the transducer is open to the atmosphere. Vented systems are known to suffer from occasional blockage and are used less frequently in hazardous environments. In addition, a record of barometric pressure is valuable for oceanographic studies, so the two-transducer option is most frequently employed.

Relatively inexpensive pressure sensors use strain gauge or ceramic technology in which changes in water pressure cause changes in resistance or capacitance in the pressure element. The most accurate, but expensive, sensors use a quartz element, the resonant frequency of which varies with the strain applied to it. The resulting signal, which is normally a frequency proportional to the applied pressure, is carried down the signal cable to the control electronics where it is converted into physical units and can be displayed and stored by a data logger.

All pressure transducers are sensitive to temperature. Some have an in-built temperature sensor to allow compensation of the pressure signal. If this is not the case, then it is important that temperature is monitored independently and used as a correction. In general, sea temperature varies much less than atmospheric temperature and compensation by either of the above methods is effective. Users with access to a test facility can also subject the instruments to a range of temperatures and pressures to ensure that calibration values are correct. Experience has shown that the calibration coefficients supplied by leading manufacturers are accurate and constant over periods of several years. Drift in the various properties of pressure sensors is confined to changes in its datum value (i.e. there is usually no change in scale). However, even for a high-quality low-pressure sensor suitable for coastal work, instrumental drift can be an important issue (of the order of 1 mm per year) which has to be addressed through regular checks of some kind.

Single transducer systems can be deployed in environmentally hostile areas where other forms of gauge will not work. For example, they can be safely positioned on the sea bed under the winter ice at polar sites with the signal cable to the tide gauge hut on the shore protected by a steel pipe. They can be operated at sites with harsh weather conditions where the exposed structures of a stilling well or acoustic gauge may be subject to extreme forces of winds and waves. In tropical locations, where equipment may be prone to mechanical damage by falling trees etc., single transducer systems can be deployed safely below the sea surface. Even in locations with excessive marine growth or silt deposits, pressure systems appear to work correctly for long periods of time.

Pressure sensors have a fast response time and have been used to measure wave heights at periods of a few seconds. In tide gauge applications, the signal is usually averaged by the control electronics to a more relevant period, such as 1, 6 or 15 minutes. This method of averaging allows a great deal of flexibility, since the sampling period can be easily altered to suit the application. Changes can be made remotely if an installation is connected by a telephone link or to a two-way communication network.

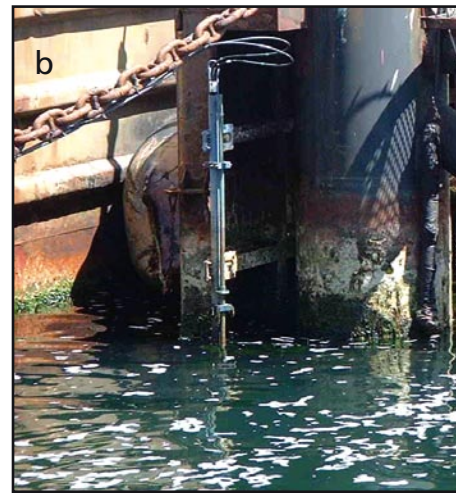
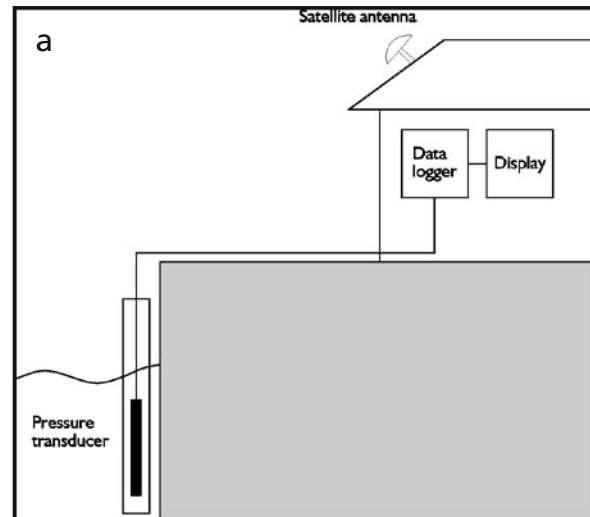

Figure 3.3 Pressure gauge.

(a) The pressure sensor is mounted directly in the sea. (b) In this case, it is fastened to a pier in Port Stanley harbour.

As with the bubbler gauge, seawater density is needed to convert measured pressures into heights. The comments made in section 3.3.1 are equally valid.

3.3.3 The Datum of a Pressure System

The major problem with a single pressure transducer is establishing a datum for its measurements. A good approximation can be obtained with differential transducers by careful calibration within a test facility. It is less accurate with absolute sensors because atmospheric pressure introduces an offset that may prevent a sufficiently low pressure being reached during the calibration. In general, other means of fixing the datum are preferred.

A method frequently adopted is to make visual measurements against a tide staff over a period of one day and repeat this at regular intervals. Individual measurements should be accurate to 2–3 cm and on average

should fix the datum to approximately centimetre accuracy. However it is tedious and can only be carried out infrequently in remote areas.

3.3.4 Multiple Pressure Transducer Systems ('B' gauges)

A method was developed at POL in the early 1990s for precise datum control of sea level records from pressure tide gauges. An additional pressure point was located at approximately mean sea level and fixed relative to the contact point of the gauge. The juncture at which the tide fell below this second sensor could be used to fix the datum of the record from the principal sensor. The technique was found to be extremely reliable and accurate and now forms the basis of gauges, called 'B' gauges, in POL's South Atlantic and Antarctic networks (Spencer et al., 1993). The principle of the technique was described in detail in Volume 2 of the Manual (IOC, 1994) and in the scientific literature (Woodworth et al., 1996). At the time of writing, it is not possible to purchase a 'B' gauge although expressions of interest in their manufacture have been obtained from major suppliers.

A schematic 'B' gauge setup is shown in Figure 3.4, with an absolute pressure sensor in the water ('C') and another in the atmosphere ('A'). Parascientific digiquartz sensors are employed throughout, although less expensive sensors should work reasonably well and are being investigated. The difference C–A gives sea level, after corrections for seawater density and acceleration due to gravity are applied. A third sensor is placed at 'Datum B' which is near mean sea level. The height of 'Datum B' has to be known accurately relative to the contact point of the installation and to the local land levelling network. The difference B–A is again a sea level height, but only when the sea level is above 'Datum B'. The top part of this record can be fitted to the equivalent part of the record from the principal sensor to transpose the known datum to the full sea level record. It is important that all sensors are driven from the same control and logging system to maintain synchrony. Sampling the data at 15-minute intervals or less is preferred for the identification of the inflexion points, i.e. the time at which the sea level falls (or rises) below (or above) 'Datum-B'.

The essential feature is that, while any pressure measured by a sensor at B will contain an offset, and perhaps a drift, the vertical height of its effective pressure point can be positioned at 'Datum B' very accurately. So, although it is not known what it is measuring to within perhaps a few hectopascals (centimetres), it is known where it is measuring with millimetric precision. The flat part of B–A and its inflexion points provide an extremely precisely defined shape which is immune to any problems with datum offsets and low-frequency instrumental drifts. Experience with several instruments

at different sites suggests that datums can be fixed to within a few millimetres by this technique.

To work properly, the method needs a sizable tidal range, so that B will spend half its time in water and half in air. It will not work in lakes or microtidal areas, but most coastal and many island sites have usable tidal ranges, even if only at spring tides. In the presence of waves, the flat portion of the 'B' gauge is reduced in length and may be unuseable under large wave conditions. However, there are always a sufficient number of calm days during which the technique can be applied.

In practice, the two pressure sensors in the sea are co-located near the base of the installation with a rigid tube connecting the 'B' gauge to its appropriate datum point. This avoids the 'B' sensor being subject to atmospheric temperature variations that are more severe than those of the sea. The barometric sensor may also be installed at the same position with a tube open to atmosphere. Alternatively it may be installed as part of the data logger in the tide gauge hut. The method does not require the actual installed height of C or A to be known. Where it is difficult to install a fixed gauge C below the water, because of shallow gradients perhaps, then a pop-up or bottom-mounted gauge could equally well be used.

3.3.5 Pressure Transducers in Stilling Wells

A variant of the 'B' gauge method described above is to install an absolute pressure sensor below low water in a stilling well that has been used hitherto in a float system. This transducer will be functionally the same as sensor 'C' and will be complemented by a transducer 'A' that records atmospheric pressure, as described above. Alternatively, a 'differential' sensor could be used. Instead of a third sensor employed in the 'B' gauge, datum control for the C–A pressure-difference time-series is provided by means of regular, preferably daily, electronic datum probe checks of the level in the well relative to the tide gauge CP and TGBM. Comparison of the values of C–A, corrected for density and acceleration due to gravity, with the well soundings, provides an ongoing datum for the time-series which can accommodate transducer drift and variations in the properties of the sea water.

This method has many of the advantages of pressure systems and of electronic datum probes, combined with the recognized disadvantages inherent in the use of stilling wells (Lennon, 1971). It may be a preferred option if measurements are required from a well that has produced long-term measurements from a float gauge.

3.3.6 Bottom-mounted Pressure Gauges

Bottom pressure gauges rest on the sea bed and record pressure at intervals over periods of a year or

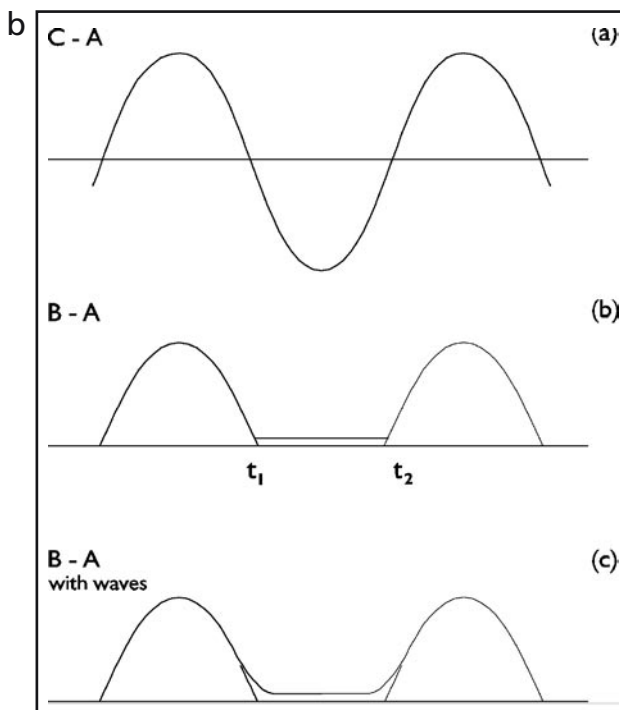
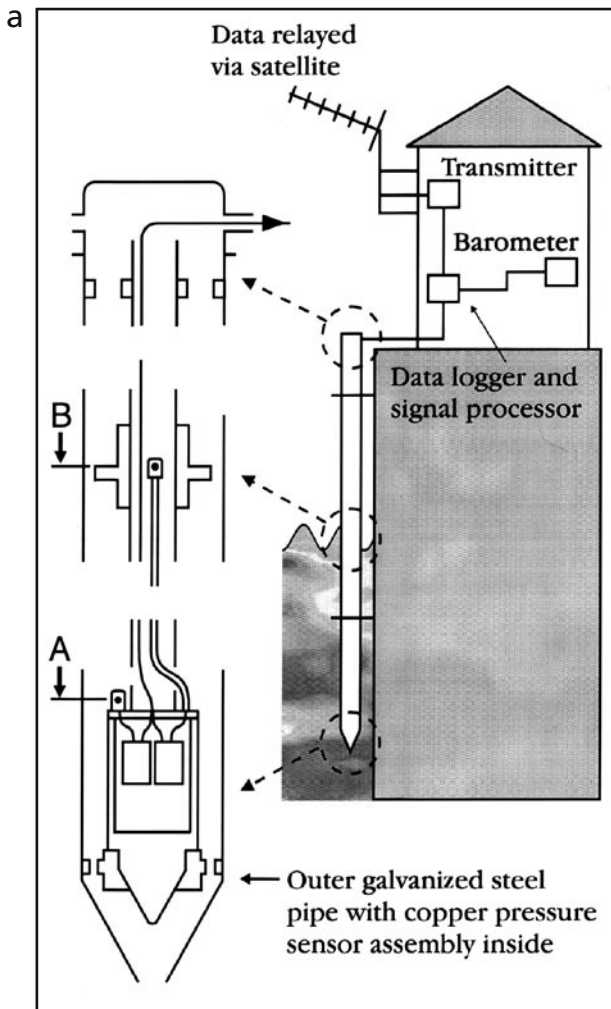

Figure 3.4 (a,b) Schematics of operation of a 'B' gauge.

more. They are self-contained instruments powered by batteries. They have little application to the long-term measurement of coastal sea level but have been used extensively to obtain initial tidal knowledge of an area where a coastal gauge is planned. Their main problem in the GLOSS context is the lack of a datum. They have principally proved their value offshore and in the deep ocean (Spencer and Vassie, 1997).

3.4 Acoustic Tide Gauges

A number of acoustic tide gauges have been developed which depend on measuring the travel time of acoustic pulses reflected vertically from the sea surface. This type of measurement can theoretically be made in the open with the acoustic transducer mounted vertically above the sea surface, but in certain conditions the reflected signals may be lost. To ensure continuous and reliable operation the sensor is located inside a tube that provides some degree of surface stilling and protects the equipment; some sensors even constrain the acoustic pulses within a narrow vertical tube, which is contained inside the previous one. This outer tube does not completely filter out wave action but, by averaging a number of measurements, the desired filtering is achieved.

The velocity of sound in air varies significantly with temperature and humidity (about 0.17%/°C) and some form of compensation is necessary to obtain sufficient accuracy. The simplest method is to measure the air temperature continuously at a point in the air column and use this to calculate the sound velocity. To account for temperature gradients in the air column, temperature sensors may be required at a number of different levels.

A more accurate method of compensation is by use of an acoustic reflector at a fixed level in the air column. By relating the reflection from the sea surface to that from the fixed reflector, direct compensation for variation in sound velocity between the acoustic transducer and the fixed reflector can be achieved. However this still does not account for any variation in sound velocity between the fixed reflector and the sea surface. To achieve full compensation would require, in principle, a number of fixed reflectors covering the full tidal range, but none of the known acoustic sensors has this possibility.

3.4.1 Acoustic Gauges with Sounding Tubes

The National Oceanic and Atmospheric Administration (NOAA), National Ocean Service (NOS) in the USA, initiated over a decade ago a multi-year implementation of a Next-Generation Water Level Measurement System (NGWLMS), both within the US national tide gauge network and at selected sites around

the world (Gill et al., 1993). These systems were operated alongside existing (float or bubbler) tide gauges at many stations for a minimum period of one year to provide datum ties and data continuity. Dual systems were maintained at a few stations for several years to provide a long-term comparison. Tide gauges using the same technology have been deployed in a number of other countries, such as Australia, where they are known as SEAFRAME systems (Lennon et al., 1993).

The NGWLMS tide gauge uses an Aquatrak water level sensor developed by Bartex Inc. and acquired by Aquatrak Corporation, together with a Sutron data-processing and transmission system. The Aquatrak sensor sends a shock wave of acoustic energy down a 1/2-inch-diameter PVC sounding tube and measures the travel time for the reflected signals from a calibration reference point and from the water surface. Two temperature sensors give an indication of temperature gradients down the tube. The calibration reference allows the controller to adjust the measurements for variations in sound velocity due to changes in temperature and humidity. The sensor controller performs the necessary calculations to determine the distance to the water surface. The sounding tube is mounted inside a 6-inch-diameter PVC protective well which has a symmetrical 2-inch-diameter double cone orifice to provide some degree of stilling. The protective well is more open to the local dynamics than the traditional stilling well and does not filter waves entirely. In areas of high-velocity tidal currents and high-energy sea swell

and waves, parallel plates are mounted below the orifice to reduce the pull-down effects (Shih and Baer, 1991). Figure 3.5 is a schematic of a typical NGWLMS installation. To obtain the best accuracy, the acoustic sensor is calibrated by reference to a stainless steel tube of certified length, from which the zero offset is determined.

The NGWLMS gauges have the capability of handling up to 11 different ancillary oceanographic and meteorological sensors. The field units are programmed to take measurements at 6-minute intervals with each measurement consisting of 181 one-second-interval water level samples centred on each tenth of an hour. Software in the instrument rejects outliers etc. which can occur as a result of spurious reflections. Measurements have a typical resolution of 3 mm. The instrument contains the necessary hardware for telephone and satellite communications.

Papers by Gill et al. (1993) describe the operational performance of the NGWLMS instrumentation. Lennon et al. (1993) and Vassie et al. (1993) present comparisons between NGWLMS and conventional stilling well or bubbler systems in Australia and the UK. Most comparisons show small differences, of the order of a few millimetres, for the various tidal and datum parameters, which are generally within the uncertainty of the instrumentation. Such differences are very small when compared to typical tidal ranges and even seasonal and interannual sea level variations. NGWLMS systems are considered sufficiently accurate for mean sea level studies.

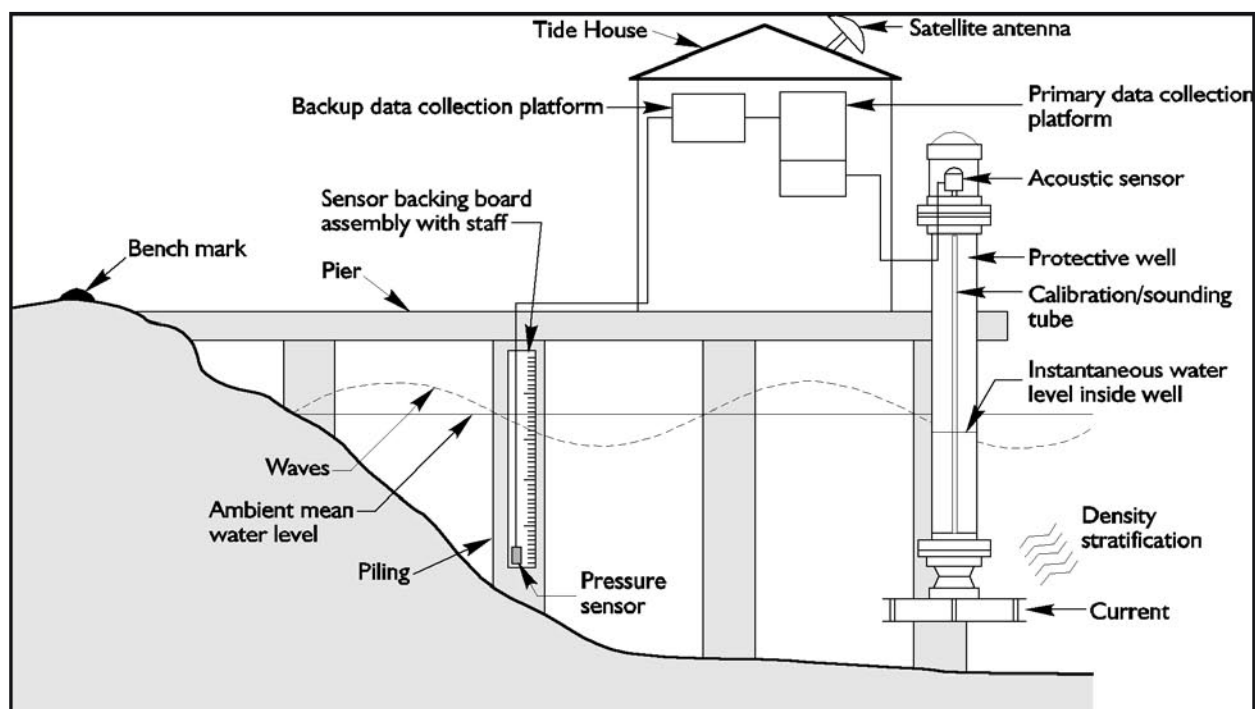

Figure 3.5 NGWLMS tide gauge.

A modern version of the NGWLMS is called a Sea Ranger which is claimed to have a number of advantages over the earlier technology including self calibration (IOC, 2004)

3.4.2 Acoustic Gauges without Sounding Tubes

Several acoustic instruments have been produced that are operated without a sounding tube, normally located inside an existing stilling well or inside a plastic tube some 25 cm in diameter. Some of them may operate in the open air, but are not normally employed for high-quality sea level measurements (see Table 3.1 in section 3.6). These acoustic instruments operate at a frequency of 40–50 kHz and have a relatively narrow beam width of 5°. Their measurement range is approximately 15 m and an overall accuracy of 0.05% is claimed by the manufacturers (see websites below).

Contradictory experiences can be found with this type of acoustic sensor, from some problems in achieving the stated accuracy under all environmental conditions (e.g. see presentation by Ruth Farre, in IOC, 2003), to the high-quality and continuous operation of 15 tide gauges in the REDMAR network (Spain), most of them installed in 1992 and still in operation (e.g. see presentation by Begoña Pérez in IOC, 2003).

A crucial aspect of this type of sensor is the dependence of the velocity of sound on the environmental conditions, such as the air temperature. On the other hand, tubes tend to increase the temperature-gradient between the instrument and the sea surface unless special precautions are taken to ensure that the air is well mixed in the tube. A complementary and necessary method is to compensate for sound velocity variations using a reflector mounted at a suitable distance below the transmitter, as is the case for the SRD gauges employed in the REDMAR network. A careful design of the installation, avoiding different ambient conditions along the tube and following the maker's requirements about the minimum distance to the water surface, become crucial for the final accuracy of the data.

The performance of one of these sensors (SRD) over an existing stilling well inside a hut or small building in Santander (Spain), has been incredibly good (nearly perfect and continuous during 15 years). The conditions of this installation are probably perfect, perhaps because the temperature inside the building is rather homogeneous. Data from this acoustic sensor have in fact helped to correct malfunctions of the float gauge that operates inside the same stilling well.

Studies of mean sea levels from 12 years of data in Spain, comparing this type of acoustic sensor (SRD) with the traditional float gauges, has shown their high quality and has even helped to identify refer-

ence jumps in the older float gauges. This is, again, a contradictory experience to the one in South Africa (see article by Farre in Appendix V of this volume). Nevertheless, it seems that radar gauges will replace this type of acoustic sensor everywhere, in the near future.

3.5 Radar Gauges

Radar tide gauges have become available during the last few years from several manufacturers. Although this technology is relatively new, radar gauges are being purchased and installed by a number of agencies as replacements for older instruments or for completely new networks. The reason is that they are as easy to operate and maintain as acoustic sensors, without their main disadvantage: their high dependence on the air temperature. Radar gauges have a relatively low cost and the engineering work necessary to install them is relatively simple compared to other systems. The instruments are supplied with the necessary hardware and software to convert the radar measurements into a sea-level height. In addition, the output signals are often compatible with existing data loggers or can be interfaced to a communication network. Like many modern systems they can be set up using a portable computer.

The active part of the gauge is located above the water surface and measures the distance from this point to the air–sea interface. A diagram is given in Figure 3.6. The gauge has to be mounted in such a way that there are no restrictions or reflectors in the path of the radar beam, between the gauge mounting and the sea surface. It has to be positioned above the highest expected sea level and preferably above the highest expected wave height, so as to prevent physical damage.

It has many advantages over traditional systems in that it makes a direct measurement of sea level. The effects of density and temperature variations, even in the atmosphere, are unimportant. The main constraint is that the power consumption may be relatively large in radar systems if used on a continuous basis in a rapid sampling mode. Averages are typically taken over periods of minutes. This may limit its use in some applications (e.g. tsunami warning) where observations are required on a continuous high-frequency (e.g. 15-second) basis. In such areas, pressure gauges may be more appropriate, although work and research is still being done concerning this particular application.

Radar gauges fall into two categories. Those that transmit a continuous frequency and use the phase shift between transmitted and received signal to determine sea level height (frequency-modulated continuous

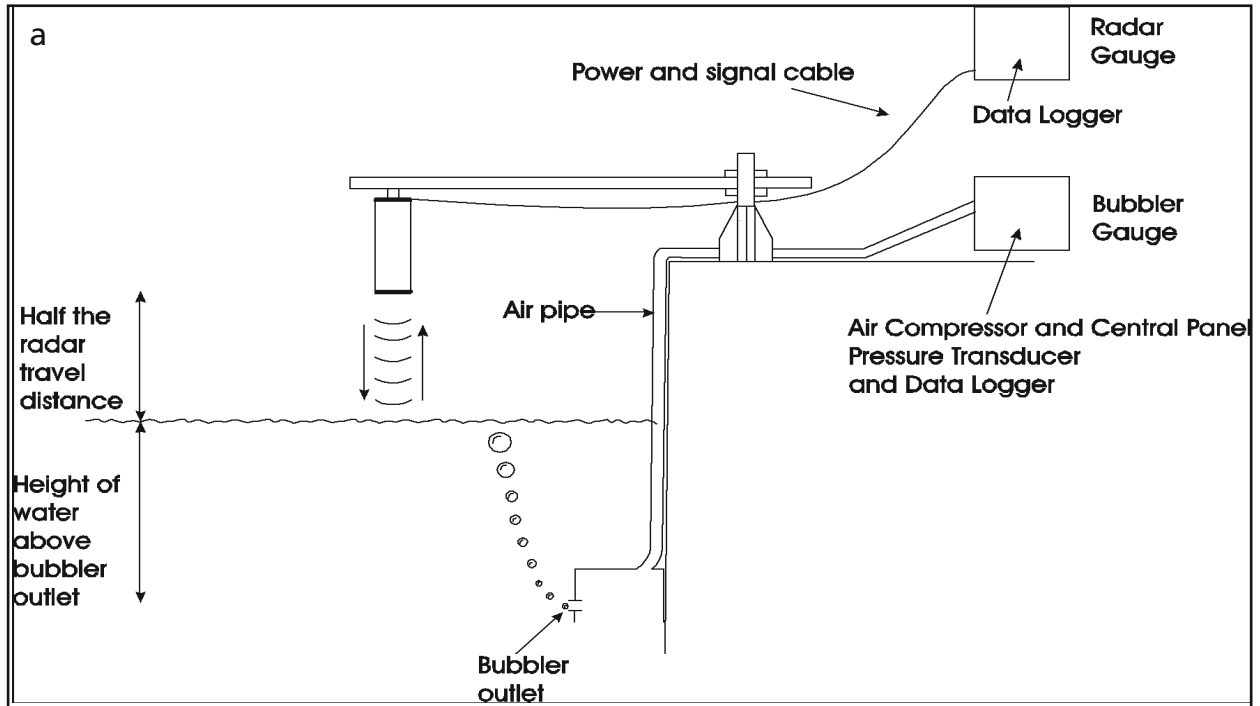

Figure 3.6 Radar tide gauges.
 (a) diagram comparing a radar and a bubbler gauge (Woodworth and Smith, 2003);
 (b) an OTT Kalesto test installation at Liverpool.

waves: FMCW). The OTT Kalesto, Miros and Radac instruments use this method. The VEGA and SEBA systems use pulsed transmissions and time-of-flight measurement. All these gauges have undergone initial tests and inter-comparisons by various agencies in different countries. Details of these tests can be found in IOC Workshop Report No 193. Details of the individual instruments can be found on the websites shown below.

In principle, the instruments are self calibrating, as far as a datum value is concerned. However, to provide confidence that the datum remains constant over long time periods, alternative means are being investigated. These take the form of a reflector that can be placed in the radar beam at appropriate intervals. The reflector is placed at a known distance below the contact point of the installation for a short period. Over a period of a year or more the datum value can be verified and used to adjust the measurements, if necessary.

Initial indications that these instruments can provide acceptable measurements for the purposes of GLOSS are promising. As with all tide gauges, practical considerations related to a particular application often dominate other considerations. For example, they have very limited application in polar regions. They have not yet been used in extremely hostile environments, for example on remote islands, where extreme waves may overtop the gauge by several metres. However, for a normal application in which a stilling well or bubbler gauge is presently in use, they appear to operate satisfactorily.

3.6 Summary of the Merits of Different Technologies

In this section, we summarize the relative merits of different tide gauge technologies for scientific research, operational oceanography and for localized practical purposes, such as harbour operations.

The GLOSS programme has scientific research as its *raison d'être*, although it is intended that the development of the GLOSS networks should serve to improve standards overall (see IOC, 1997). We can use the designation 'GLOSS' to indicate the most demanding requirement of scientific-quality performance of a gauge (Appendix I).

There are also sea level requirements from operational users of oceanographic data in such topics as marine infrastructure (e.g. offshore industry, transport, coastal recreation) and coastal defences (e.g. flood protection from surges, and studies of coastal erosion or sea level rise impacts). Many of these applications overlap GLOSS interests, the

study of secular changes in sea level being an obvious example. However, the particular applications will vary from country to country. Therefore, such gauges will be capable of deployment for extended periods, but perhaps not to the same high standards as those intended for GLOSS, and will be affordable for use in larger numbers than for GLOSS, especially by developing countries.

Finally, there will be applications which require a cheap instrument capable of showing the state of the tide at any moment but certainly not accurate enough for GLOSS.

Table 3.1 presents a summary of the main conclusions on the relative merits of each gauge technology based on the previous sections of this Manual. The Table also includes an estimate of the likely cost of a basic system with gauge, data transmission (e.g. modem) and meteorological package, although this is an extremely difficult item to quote given the large number of manufacturers, monetary exchange rates etc. For example, the cost of a pressure transducer will vary by a factor of 3 depending on the quality. With these reservations in mind, Cost Band 3 has been set as the highest cost, which might be 12,000–20,000 US\$ (at the time of writing and within a large band, say 30%); Band 2 might be 8,000–12,000 US\$; and Band 1, 5,000–8,000 US\$. However, in our experience, the real costs of any tide gauge station are those of installation (e.g. some kind of engineering support will be needed for installation of a stilling well, acoustic sounding tube gauge, or 'B' gauge; diver support will be needed for pressure gauge installations etc.), ongoing maintenance and data analysis (with implications for staff resources). Anyone planning a gauge installation has, therefore, to take into account all the local costs as well as the up-front costs of gauge hardware. Agencies participating in GLOSS which require the input of expertise may wish to explore the possibilities of collaboration with other GLOSS participants.

Our recommendations are:

- If one is planning a new GLOSS tide gauge station in a mid- or low-latitude location, one should probably opt for:
 - an acoustic gauge with sounding tube or
 - a radar tide gauge or
 - a 'B' pressure gauge

If low tidal range or other factors preclude the use of a 'B' gauge, then a single transducer pressure gauge, a bubbler pressure gauge or a pressure transducer in a stilling well would be options. In addition, in most cases, the main tide gauge should be accompanied by a pressure sensor installed in the sea and capable

of sampling (or averaging) at the high frequencies (once every 15 seconds or 1 minute) required for tsunami-warning purposes, although, in the case of some of the FMCW radars, this high frequency is also possible at the main tide gauge. The advantages of running two or more sea level sensors in parallel are also: (i) improved data recovery; (ii) improved data quality assessments by comparing redundant records; and (iii) ability to optimize sampling strategy for different processes. Real time data from GLOSS sites need to be made available in real time to the GLOSS Real Time Centre at the University of Hawaii.

- If one is planning a new GLOSS station at a higher-latitude site which has sea ice cover for part of the year, one should probably opt for:
 - an absolute transducer pressure gauge and accompanying barometer
 - a bubbler pressure gauge

Although it is true to say that float gauges have been operated in Antarctica, and the longest tide gauge record in Antarctica is from the Faraday/Vernadsky float gauge in a heated stilling well, we do not recommend their future use in ice areas. Bubbler and acoustic gauges have also been tried in Antarctica, but our recommendation is to use the absolute transducer system if possible, with summer-time datum control using either tide poles or 'temporary B gauges'.

- If one is planning to upgrade an existing float gauge GLOSS installation at most places, then we would recommend the following approach.

First, consider simply upgrading the existing system to electronic data acquisition and transmission. (Charts must be abandoned as the main recording system, although they may be retained to provide ancillary information.) This will provide instructive experience with real time data.

Second, consider the use of a pressure gauge system within the stilling well.

Third, consider installation of a new station alongside the old one (either acoustic sounding tube, radar or 'B' gauge etc. as described above) but keep both of them operational for inter-comparison of their data for an extended period (possibly as much as a decade). Probably, the installation of a radar gauge over the well would be the easier option.

- If one is planning to use relatively cheap gauges (but perhaps many units) for 'coastal' purposes, then we would recommend:
 - single-transducer pressure gauges (either absolute or differential)
 - if existing (or easily installed) stilling wells are available, fairly inexpensive shaft encoder float systems are now on the market
 - if stilling wells are available, pressure transducers in the well
 - cheap radar gauges (normally pulse technology), both in the case of existing stilling wells or in the open air.
- If one required a 'cheap and cheerful' gauge for 'practical' harbour operations or approximate flood level estimates, then we would recommend:
 - differential transducer pressure gauges
 - cheaper radar gauges.

Such installations would not need the ancillary parameters needed for GLOSS (Appendix I, point vi), but they may require such components as 'user friendly' real-time displays.

Whichever type of gauge is selected, advice will be needed, and groups such as the PSMSL and the GLOSS Technical Committee will be pleased to help. Something important to take into account is the correct installation and a good knowledge, by the maintenance technicians, of the problems that any particular sensor can present and how to avoid them with adequate operation.

Table 3.1 Merits and drawbacks of each tide gauge technology.

Acoustic Gauges with Sounding Tubes	
Equipment	Complete ready-to-go package (acoustic transducer, sounding tube, met. package, ancillary sub-sea pressure sensor, modem and satellite communications) can be purchased from several manufacturers.
Operation	The device measures the time of flight of an acoustic pulse along a vertical sounding tube. Transit time is compared to a reflection from a calibration hole at a known distance from the acoustic transducer to obtain sea level height. Sound velocity is temperature-sensitive, therefore temperature is measured in the support tube by two thermistors mounted some distance apart.
Installation Requirements	The length of the sounding tube is altered to suit the application. The sounding tube is fastened to an Aquatrak acoustic transducer and inserted in an outer protective stilling tube. The full assembly is then fixed to a vertical sea wall. Mains power or batteries and solar panels. An auxiliary pressure sensor is normally fitted as part of the installation. This is a vented cable-type transducer.
Location	Requires a sea wall or vertical structure for installation.
Calibration	Calibration is performed during manufacture prior to delivery.
Accuracy	Better than 1 cm of sea level.
Cost	Bands 2–3.
Record of Use	Used extensively in the United States as a replacement for bubbler systems in the National Tide Gauge Network. Used in a large part of the Australian network and at island sites in the Pacific Ocean.
Comments	For best accuracy, a calibration facility is required. In areas of large tidal range, a long sounding tube is needed which may result in magnified temperature and/or temperature-gradient effects.

Acoustic Gauges in the Open Air	
Equipment	A ready-to-go package can be purchased from several manufacturers.
Operation	The device measures the time of flight of an acoustic pulse from a transducer to the sea surface. The time is converted to a sea level height using a known value of the velocity of sound in air. Sound velocity is temperature sensitive, which can cause significant errors if it is not taken into account.
Installation Requirements	The installation requirements are relatively simple. The device requires a rigid structure to position it above the sea with sufficient clearance to avoid spurious reflections from any adjacent structures. As with many tide gauges, all ancillary equipment (data logger, modem, satellite communications, battery backup), needs to be housed in an adjacent building.
Location	Requires a site with vertical clearance sufficient to mount the device clear of the maximum sea surface, including wave action.
Calibration	Accurate calibration is one difficulty because of the sensitivity of sound velocity to air temperature. A calibration can be achieved by placing a reflective bar at a known position in the acoustic beam. The results are usually inferior to the sounding tube method.
Accuracy	Greater than 1 cm of sea level.
Cost	Band 1.
Record of Use	Without independent confirmation of the accuracy and datum, these gauges are less applicable for GLOSS purposes. They have been used successfully on offshore rigs to record sea level over periods of several years.
Comments	For best accuracy an independent calibration method is required. In areas of large tidal range, or where the transducer is high above the sea surface, there are secondary effects caused by the acoustic beam sounding different surface areas of the sea at the peak and trough of a wave.

Acoustic Gauges without Sounding Tube inside Protective Tube or Well	
Equipment	A ready-to-go package can be purchased from SRD that includes the sensor, the data logger and configuration unit, and the communications system.
Operation	The device measures the time of flight of an acoustic pulse from a transducer to the sea surface. A bar is fixed at a known distance from the transducer, which is used for self-calibration and computation of the velocity of sound before each measurement. The time is converted to a sea level height using the value of the velocity of sound in air previously computed by means of the fixed bar.
Installation Requirements	This type of acoustic sensor has proved to be accurate enough if placed over an existing well, or inside a protective PVC tube of 300 mm diameter. The transducer must be located at a minimum distance of around 2–3 metres from the water surface at any moment. As with many tide gauges, all ancillary equipment (data logger, modem, battery backup), needs to be housed in an adjacent building.
Location	Requires a sea wall or vertical structure for installation.
Calibration	Calibration of the reference is performed during manufacture, prior to delivery. The calibration of the velocity of sound is made by means of the reflective bar at a known position in the acoustic beam.
Accuracy	1 cm of sea level.
Cost	Band 2.
Record of Use	They have been used successfully in the REDMAR network, the Spanish Harbour Authority's sea level network, for nearly 16 years. The long-term means seem to be as accurate or better than the standard float gauges operating in Spain.
Comments	In areas of large tidal range a long protective tube is needed which may result in magnified temperature and/or temperature-gradient effects. Very sensitive to the careful design of the installation.

Single Transducer Pressure Gauges	
Equipment	Complete ready-to-go package (sub-sea pressure sensor, cabling and data logger) can be purchased from several manufacturers.
Operation	Two different options are available: (a) an absolute pressure sensor measuring the total pressure due to sea level and atmosphere; (b) a differential sensor which has a vented cable measuring pressure changes due to sea level alone. Conversion of pressure to sea level height requires knowing seawater density. Generally, an average value can be used unless there are significant seasonal or tidal variations. Pressure sensors are also temperature sensitive, but, since sea temperature varies much less than atmospheric temperature, this normally has a small effect. Sensors vary in cost by up to a factor of 20. Relatively inexpensive sensors use strain gauge technology. Top-of-the-range sensors are constructed using quartz crystals. For the latter, the temperature sensitivity of low-pressure sensors is around 1 mm/°C. Instrumental drift of the same sensor is about 1 mm per year. Many pressure sensors produce a frequency-modulated output. This can be counted (integrated) by relatively simple electronics to produce the required measurements. Resolution therefore depends on the integration period, which is typically 15 or 6 minutes, but can be as short as 1 minute and still provide sufficient accuracy. Some manufacturers provide equipment that does not integrate over the full sampling interval, in order to conserve battery power.
Installation Requirements	These devices can be used virtually anywhere, even on shelving beaches. They are normally mounted in an outer protective tube fastened to a sea wall but can be fixed directly on the sea bed and connected to the shore by armoured cable. Pressure sensors require very little power and can be run for periods of 1–2 years on non-rechargeable batteries.
Location	Pressure sensors can be used at virtually any site, even in hostile environments, such as the polar regions. Regions with large variations in seawater density may cause significant errors.
Calibration	Calibrations traceable to National Physical Laboratory (UK) standards can be obtained from pressure sensor manufacturers and have been shown to remain stable over many years. However, drift in the datum value of a sensor may cause changes to its 'zero' value. Re-calibration at intervals may be necessary. Alternatively, the difficulty of establishing a datum can be rectified by using alternative means (e.g. from annual tide pole measurements). These have proved adequate, since the drift is normally linear with time.

(Continued on next page)

Accuracy	Resolution of a low pressure sensor is typically better than 1 mm of sea level. However, instrumental drift may degrade this, so that the accuracy is approximately 1 cm of sea level.
Cost	Varies by a large factor depending on type. Band 1–2.
Record of Use	Used frequently as a temporary exploratory tide gauge. Extensively used at remote island sites and in hostile environments, such as the Antarctic.
Comments	Datum fixing is the major problem and other types of tide gauge are preferred for permanent installations.

Multiple Pressure Transducer Systems (B Gauges)

Equipment	These instruments are used only by POL and were developed to produce a high precision tide gauge. They are constructed in-house from commercially available components but cannot be obtained as a complete ready-to-go package. The instrument requires three high quality pressure transducers which results in a relatively expensive system. A less expensive construction is presently being considered.
Operation	The instrument contains three pressure sensors which measure respectively a) atmospheric pressure b) Half-Tide pressure and c) Full-Tide pressure. All three sensors are positioned in the sea with a rigid tube to the appropriate measuring point above. Since the position of the top of the Half-Tide tube is known accurately this can be used to calibrate the datum of the Full-Tide pressure. Data is fed by an armored cable to a data logger and control unity sited nearby. Most of the comments relating to a single pressure sensor are applicable but drift in the pressure sensors is inconsequential to its operational capability. Temperature compensation of the pressure sensors is obtained from components integrated into the pressure sensors.
Installation Requirements	The instrument is pre-assembled and requires fixing to a vertical sea wall or marine structure.
Location	Requires a sea wall or vertical structure for installation.
Calibration	Manufacturers calibrations of the pressure sensors are sufficiently accurate. The Half-Tide point should be levelled to local benchmarks.
Accuracy	Precision and accuracy of a few millimetres has been achieved.
Cost	Band 3.
Record of Use	Used in the United Kingdom and extensively at remote island sites in the Atlantic as well as in the Antarctic.
Comments	Extremely accurate system with automatic datum control and as a by-product air pressure, air temperature and sea temperature are recorded. For operational reasons the instrument will only work in a region where the tidal range is 1 metre or greater.

Pressure Transducers in Stilling Wells

Equipment	Pressure transducers are often placed in stilling wells, where these are available. This provides a protected and secure environment for the sensors and can augment measurements made by a float gauge. The comments above on pressure sensors are equally valid for this type of installation.
Accuracy	Approximately 1 cm of sea level. The absolute accuracy may be limited by the characteristics of the stilling well.
Cost	Band 2.
Comments	Problems associated with the use of stilling wells are well documented. (see Float Gauges).

Bubbler Pressure Gauges

Equipment	Complete systems are available commercially, but considerable assembly work is required to construct an operational tide gauge. The equipment comprises an air supply (normally from a compressor), a gas control system, a connecting pipe, a sub-sea pressure outlet, a pressure transducer at the landward end and the various data logging and support electronics.
Operation	The instrument supplies air from the high pressure supply at a reduced pressure and at a constant rate through the system. The pressure required to bubble the air through the sub-sea outlet at this rate is a measure of the sea level above the outlet. A differential pressure transducer vented to the atmosphere alleviates the need to measure atmospheric pressure separately, thereby producing a pressure reading proportional to sea level height. The sub-sea outlet is open at the base, has a large surface area relative to its volume and has a small exit port approximately half way from the base. This design reduces the effect of wave action and provides a very stable datum.
Installation Requirements	The outlet and part of the connecting tube are the only components in the sea. Such a configuration increases the reliability of the system and makes replacement relatively simple. All other components of the system are housed nearby. The system requires external power for continuous operation, and backup operation is relatively limited, owing to the limited air supply.
Location	Bubbler systems can be used at virtually any location, even on shelving beaches. Connecting tubes can be several hundred metres in length. As with most pressure measuring systems, regions with large variations in seawater density may cause significant errors.
Calibration	Calibration is concerned with the pressure sensor accuracy and may need to be repeated at intervals. Calibrations supplied by leading pressure transducer manufacturers are acceptable provided occasional means of fixing the datum value are used.
Accuracy	In general, an average accuracy of 1 cm of sea level is achievable, but this may degrade under large-wave conditions.
Cost	Band 2.
Record of Use	Used extensively in the United States and the United Kingdom for their national tide gauge networks.
Comments	At a few locations, a secondary bubbler system has been installed at the mid-tide level as part of the United Kingdom network. This can be used to fix the datum of measurements in the same fashion as the 'B' gauges discussed above.

Float Gauges	
Equipment	A float in a stilling well is the tried and tested method of measuring sea level directly, rather than through an indirect parameter such as pressure or sound.
Operation	A stilling well filters out wave activity at periods shorter than the maximum tidal period, which might be 2 hours in shallow water regions. In modern installations the float drives a shaft encoder or potentiometer the output of which is fed to an electronic data logger. In the past, chart recorders were extensively used, but are no longer acceptable as the principal data-recording method, as they contain many sources of inaccuracy and require labour-intensive digitization.
Installation Requirements	Stilling well installations require heavy civil engineering work in areas of large tidal range. Many stilling wells exist throughout the world, as they are of robust construction, but new installations are less common, owing to the engineering cost. A suitable building is required above the well to protect the well and its associated measuring equipment.
Location	Requires a sea wall or vertical structure for installation.
Calibration	Stilling wells can suffer from several defects which have been well documented. For example, density variations between the inside and outside of the well in regions of stratification cause errors. Siltation and marine growth can cause changes to the dynamic response of the well. Absolute calibration usually involves dipping the well with a calibrated tape at periodic intervals.
Accuracy	Approximately 1 cm of sea level.
Cost	Band 1–2.
Record of Use	Used extensively in the United States and the United Kingdom for their national tide gauge networks.
Comments	Stilling wells have been used worldwide for a considerable period and are still used, both as the primary system and as backup system for a modern tide gauge.

Radar Gauges	
Equipment	Radar tide gauges have so far been little used for GLOSS purposes, because it is a very recent technology. However, they offer a complete ready-to-go package which is relatively easy to install above the sea surface and seem to have advantages with respect the acoustic sensors.
Operation	Radar gauges measure the time of flight either from a pulsed radar or the phase change between a transmitted and received carrier wave, to determine the distance to the sea surface. They are much less affected by air temperature than acoustic gauges.
Installation Requirements	The installation requirements are relatively simple. The device requires a rigid structure to position it above the sea with sufficient clearance to avoid spurious reflections from any adjacent structures. As with many tide gauges, all ancillary equipment (data logger, modem, satellite communications, battery backup), needs to be housed in an adjacent building. No need of a protective tube.
Location	Requires a site with vertical clearance sufficient to mount the device clear of the maximum sea surface, including wave action.
Calibration	In essence the device is self calibrating. However, for GLOSS purposes, a reflective target is mounted at a known distance below the radar transmitter.
Accuracy	Accuracy is expected to be approximately 1 cm of sea level.
Cost	Band 2–3.
Record of Use	So far these gauges have been used for relatively short periods experimentally by Spain and the United Kingdom.
Comments	Radar tide gauges may consume excessive power if used in a continuous mode. In burst mode, they provide sufficient accuracy for measuring most tidal parameters, but their use in a rapid sampling mode may be limited by this, although tests are being made in Spain for higher-frequency sampling.

4. Datum Control and Levelling

It should be clear that the measurements made by a tide gauge provide the relative movement of the sea level with respect to the land. Of course, neither land nor sea levels are constant over long periods of time. There are vertical movements of the land associated with a range of natural processes, such as co-seismic activity (earthquakes), in addition to glacial isostatic adjustment (post-glacial rebound) and plate tectonics and with a range of human activities (e.g. ground water pumping). For a review of the geological signals in tide gauge records, see Emery and Aubrey (1991). Long-term changes in sea level relate to variations in ocean currents, to changes in the volume of water in the oceans and therefore to climate change. It is clear that, to understand sea level changes properly, the different sea level and land signals have to be decoupled. This is achieved by careful definition of the tide gauge datums, by local levelling procedures, and by making independent measurements of changes in the land levels, using modern geodetic techniques. Such techniques derive from the use of very high resolution GPS receivers and absolute gravimeters.

4.1 Datums and Benchmarks

For sea level observations, a land benchmark is used as the primary reference point. The benchmark is a clearly marked point located on a stable surface, such as exposed rock, a quay wall or a substantial building. When a benchmark is on a horizontal surface, it normally takes the form of a round-headed brass bolt, the highest point of the domed head being the reference level (Figure 4.1). When on a vertical surface, it can

be in the form of a horizontal groove in the surface or on a metal frame attached to the surface, having a horizontal reference edge to which a measuring staff support can be fixed.



Figure 4.1 A brass bolt benchmark at Newlyn, UK, which functions as a reference point for height measurements in the UK and as the TGBM of the Newlyn gauge.

It is poor practice to depend upon the stability of a single benchmark. It is recommended that there be a minimum of five within a few hundred metres, or at most one kilometre, of the tide gauge. These should be connected individually by high-precision levelling and shown to maintain the same relative elevation as time progresses. If no changes are observed over long periods, it is safe to assume that the area of land around the gauge is 'stable'. The area could, of course, exhibit vertical movement with respect to a much wider area. This can be demonstrated by wide-area levelling or from surveys using space geodetic techniques.

It is desirable, although not essential, that all benchmarks be tied into a country's national levelling network, and periodically checked with respect to that network. The benchmarks will then be given elevations referred to the datum of the national network. However, national levelling networks tend to be redefined at intervals. For that reason, in sea level studies, it is best not to rely on national levelling for any scientific purpose, although,

of course, it may provide useful ancillary information. It is important that the benchmarks be clearly identified, by the inscription of a name or number. In addition, they should be unambiguously documented in the tide gauge metadata, with a description of the mark itself, photographs, national grid reference and a local map.

4.1.1 Tide Gauge Benchmark (TGBM)

The tide gauge benchmark (TGBM) is chosen as the main bench mark for the gauge from the set of approximately five marks described above. The TGBM is extremely important, since it serves as the datum to which the values of sea level are referred. The choice of TGBM is somewhat subjective; in principle, it should be the 'most stable' or 'most secure' mark of the set, although, if the area is largely stable, then the choice should be fairly arbitrary. Often the nearest mark to the gauge is chosen. Over a period of time it may be necessary to redefine the TGBM, if the original is destroyed as a result of local development. The benefit of having a set of five local marks, regularly interconnected by high-precision levelling, is that it allows a new TGBM to be defined in terms of the old one, if circumstances require it.

In some countries the historical practice has been not to define one mark as the TGBM, but to use a weighted average of several marks. For GLOSS, it is recommended that the single, unique TGBM approach be adopted as the standard.

4.1.2 GPS Benchmark (GPSBM)

The GPS benchmark (GPSBM) is another special mark of the available set that is the reference mark for GPS measurements near the gauge. In some busy ports, the GPSBM may be several hundred metres from the TGBM and the gauge. As with the other marks, it must be connected by high-precision levelling to the TGBM at regular intervals. (See section 4.4.1 for details on GPS measurements at tide gauges).

4.1.3 Gauge Contact Point (CP)

The contact point (CP) of a tide gauge is a type of 'benchmark', or vertical reference mark, associated with the gauge itself. After a geodetic connection has been made between the TGBM and the CP, the gauge's sea level data can be expressed in terms of the TGBM datum. The essential point to note is that the CP comes with the gauge; if a different type of gauge is installed at the site, it will have a different CP which will require re-levelling to the TGBM.

For conventional float and stilling well gauges, the CP is often located at the top of the well inside the tide gauge hut. Sometimes, in older stations, the CP is located in a most difficult and inaccessible location

for levelling purposes and new stations should take care to provide ready access. For acoustic gauges with sounding tubes, the CP is located at a point at the top of the gauge on the container holding the acoustic transducer. Similarly, for radar gauges, the CP will be a mark on the transducer. For 'B' gauges, the CP will be at the top of the vertical supporting tube which is known relative to the 'B' datum level.

In the case of float gauges located in a tide gauge hut, the CP should not be used as the TGBM itself, as it is always possible for the building and the well to gradually settle over a long period. With a good set of local benchmarks, this settling will be evident by check levelling between TGBM and CP.

4.1.4 Tide Gauge Zero (TGZ)

The tide gauge zero (TGZ) is the level for which the gauge would record zero sea level. In practice, the sea level may not fall to this level. In a conventional float gauge arrangement, the TGZ can be related to the CP after dipping checks in the well have been performed. This is done using a calibrated tape set to zero at the CP. Measurements are made by lowering the tape until it reaches the water and an electrical circuit is completed. The level of sea water in the well can then be related to the CP and to all other local datums.

4.1.5 Revised Local Reference (RLR) Datum

The revised local reference (RLR) datum at a gauge site is a datum defined as a simple offset from the TGBM, such that values of sea level expressed relative to the RLR datum have numerical values around 7,000 mm. The concept of the RLR datum was invented by the PSMSL so that long time-series of sea level change at a site could be constructed, even if parts of the time-series had been collected using different gauges and different, but geodetically connected, TGBMs. The approximate value of 7,000 mm was chosen so that the computers of the time (the late 1960s) would not have to store negative numbers. The RLR datum is defined for each gauge site separately and the RLR at one site cannot be related to the RLR at any other site, without additional knowledge of connections between TGBMs at the different sites.

When sea level data are contributed to the PSMSL, or to a sea level centre, it is essential that full information on the geodetic relationships between TGBM and TGZ etc. accompany the data. Without this information, it is impossible for the PSMSL to include such data in the RLR data set.

4.1.6 National Levelling Network

Most countries have, during the last one hundred years, implemented national levelling networks that are defined usually in terms of mean sea level (MSL) at one

or more stations. Levelling connections within these networks then allow the heights of objects (e.g. mountains) to be related to MSL at the coast. For example, the UK national levelling network expresses heights in terms of 'Ordnance Datum Newlyn' (ODN), which was the average level of the sea at Newlyn in southwest England during 1915–21. ODN can be thought of as an imaginary datum plane extending over a large area (i.e. over the whole of Great Britain). The heights of bench marks, for example, can be expressed in terms of ODN as can, therefore, the Chart Datum at the port.

The concept of a national levelling network has undergone revolutionary change during the last decade, primarily due to the advent of GPS. However, it was already a defective concept from the point of view of sea level studies, for several reasons. First, sea level has risen at Newlyn since 1915, as it has done at many other places around the world, so ODN no longer represents the present average Newlyn levels. Second, the mean sea surface around a coast is not 'flat', i.e. it does not follow the geoid, but varies due to ocean currents, density differences, meteorological effects etc. Consequently, MSL was never a perfect choice for a national datum plane. Third, rates of change of MSL are different at different locations, thereby complicating the time-dependence of the network. Fourth, all national levelling networks (with the possible exception of that of The Netherlands, Finland and Sweden) contain multi-decimeter errors due to systematic, instrumental errors in the levelling. Fifth, as levelling networks tended to be redefined at intervals, their redefinition in itself was a potential source of error, as 'heights' were redefined.

Consequently, while interaction between sea level specialists and national surveyors is inevitable, we advise most sea level specialists to take great care with the concept of a national levelling system.

4.1.7 Chart Datum

The chart datum (or Admiralty Chart Datum in the UK) is the low-water plane below which the depths on a nautical chart are measured and above which, tidal levels are often presented for practical purposes, such as tide tables for harbour operations. The chart datum is a horizontal plane over a limited area and the elevation of this plane will vary around the coastline, depending on the tidal ranges at the places considered. In the UK, the chart datum at a port is the same as 'Lowest Astronomical Tide' (Pugh, 1987).

4.1.8 Working Datums

Practical working datums are often used in ports where they describe sea level (or water depth) more clearly than perhaps a scientifically rigorous reference to a benchmark. Examples of such datums include the levels of the sill of a lock or a shallow point in the

entrance to a harbour. The sea level from a tide gauge then indicates the depth of water above these hazards. Working datums often functioned as the first TGBMs for Europe's sea level records (e.g. the 'Old Dock Sill' datum at Liverpool).

4.2 Levelling Between Local Benchmarks

High-precision levelling will need to be made between all the marks of the local network at regular intervals. For GLOSS purposes, the recommendation is that the exercise be repeated at least annually, with results fully documented by the responsible agency. The exact frequency of required levelling will depend on the geology of the area. On unstable ground, more frequent levelling may be necessary.

Personnel familiar with the best practices of the technique should perform levelling with a good-quality level and staff. For example, if marks are far apart, it will be necessary to establish 'staging points' clearly identified and about 50 m apart on a hard surface. This can be done by painting a small ring around the point and, on softer surfaces, by driving in a round-headed pin. The levelling instrument can then be set up between a benchmark and the first staging point and readings of the staff taken at the two positions. This is then repeated throughout the whole network. It is important that the pairs of readings be taken in the correct sequence, otherwise an erroneous height difference will result. Modern levelling instruments with built-in data loggers can remove most of the tedious arithmetic associated with the use of a simple level.

As with many other aspects of tide gauge operations, the main principle of levelling is that 'practice makes perfect'. For advice on good levelling methods, the PSMSL website (www.pol.ac.uk/psmsl) contains a set of notes used by Prof. Charles Merry at the University of Cape Town GLOSS Training Course in 1998.

4.3 Levelling Between Wider Area Marks

The height of the TGBM should also be related to a wider area network extending typically 10 km. This provides a verification of whether the sea level measured relative to the TGBM is consistent with that of the surrounding area.

First-order geodetic levelling is accurate to 1 or 2 mm over distances of a few kilometres and, therefore, annual campaigns can detect any vertical movements of the TGBM with respect to the local benchmarks.

Levelling over longer distances has been found to contain significant systematic errors that can cause apparent spurious changes in the height of the TGBM. For this reason the PSMSL requires MSL data to be defined with respect to the TGBM rather than with respect to national datum levels.

Consequently, while it is desirable in principle to perform regular wide area levelling, their accuracy has always to be considered, especially as the areas considered become wider. At a distance of some 10 km, the errors involved in levelling become comparable to those achievable by means of space geodetic techniques. Therefore, while the choice of technology for the wider area surveys is clearly evolving, the principle that the relative sea level measurements provided by the gauge data are applicable to studies for the surrounding area is still valid. Table 4.1 summarizes the accuracy obtained by the different techniques.

Table 4.1 Accuracy of geodetic fixing of TGBMs.

Technique	Accuracy
Primary Levelling of Local Benchmarks	0–1 km: <1 mm 1–10 km: <1 cm
GPS from TGBM to SLR/VLBI Reference Frame	<1 cm
Absolute Gravity near Tide Gauges and at SLR/VLBI Station	<2 μgal (approx. 1 cm)

4.4 Geodetic Fixing of Tide Gauge Benchmarks

4.4.1 Introduction

Over the past decade, advances in modern geodetic techniques have provided new methods for fixing tide gauge bench marks. These are the techniques of space geodesy, using the satellites of the Global Positioning System (GPS) and those of the Doppler Orbitography and Radiopositioning Integrated by Satellite (DORIS) system. Absolute gravity measurements provide collateral evidence of vertical crustal movements. The space geodesy measurements can be used to fix into a geocentric reference frame the GPSBM, which should be connected to the TGBM by levelling. Therefore, the MSL at the tide gauge can be defined in a global geocentric reference frame. This furnishes an absolute measure of mean sea level, rather than MSL relative to each local TGBM, or even to the wider surrounding area. Measurements of sea level are then defined in the same geocentric reference frame as that used for satellite altimetry and can therefore be directly compared with altimetric sea levels.

Repeated space geodesy measurements at a tide gauge, annually over a decade for example, enables the vertical crustal movement to be determined and therefore removed from the mean sea level trend to give the true sea level change due to climatic influences. Measuring changes of gravity near the tide gauge using an absolute gravimeter allows a completely independent determination of any vertical crustal movements. Figure 4.2 shows a schematic diagram of a local levelling network within a tide gauge system to measure absolute sea levels.

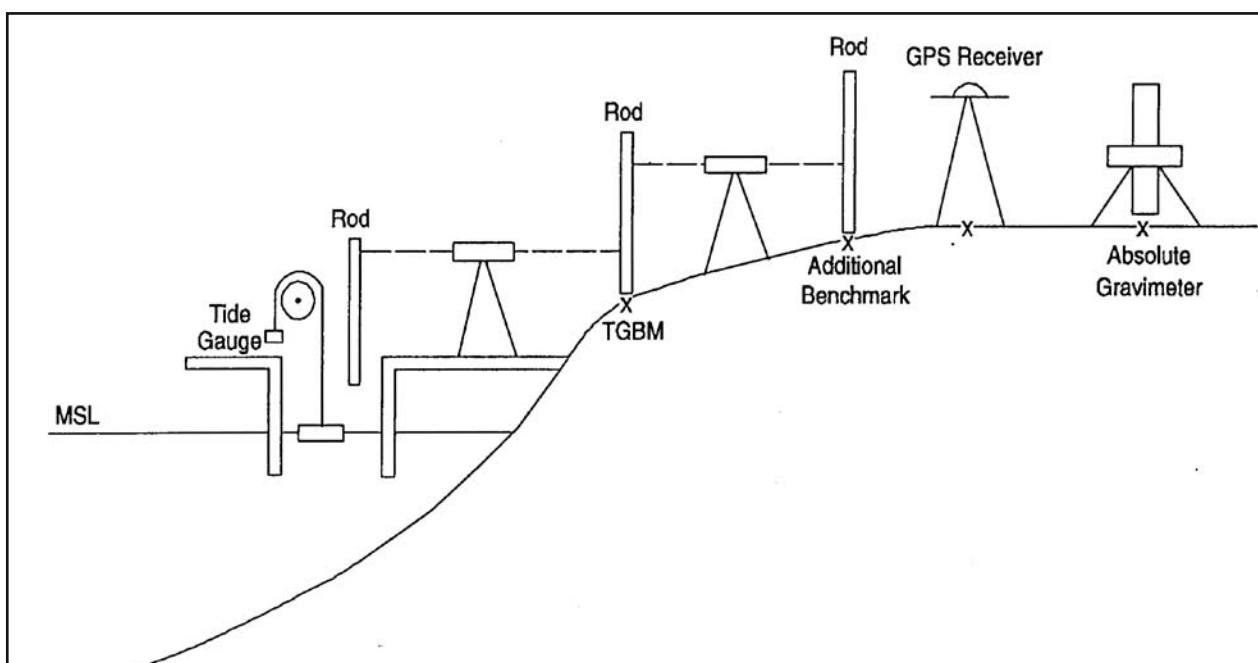

Figure 4.2 Schematic of levelling required between various benchmarks at a tide gauge station.

An international working group was set up in the late 1980s by the International Association for the Physical Sciences of the Ocean, under its Commission on Mean Sea Level and Tides, to recommend a strategy for the geodetic fixing of tide gauge bench marks. These resulted in the 'Carter reports' (Carter et al., 1989; Carter, 1994). The following sections provide a summary and describe recent developments. The reader is referred to Neilan et al. (1998) and Bevis et al. (2002) for further details.

4.4.2 GPS Measurements

Over the past decade, the GPS technique has developed rapidly to the extent that it is of fundamental importance to many areas of geophysical research (see links documented on the PSMSL training web page). The International GNSS Service (IGS) receives data from a global network of GPS stations and produces information on the orbits of the GPS satellites which is significantly more precise than the ephemerides routinely transmitted by the satellites themselves. This information is employed by researchers to produce precise positioning computations. GPS data from the IGS network are archived at the IGS Central Bureau.

Ideally, all tide gauge sites should be equipped with a permanent continuous receiver (CGPS). However, in practice, the financial resources required are often large. Many countries adopt the procedure of installing permanent GPS receivers at strategic tide gauges and then densifying the network with regular GPS campaign measurements (Neilan et al., 1998). There is clearly an advantage in concentrating CGPS work at sites with long duration PSMSL RLR mean sea level records. The GLOSS Implementation Plan refers to this set as the GLOSS Long-Term Trends (GLOSS-LTT) network. The campaigns can then concentrate on other tide gauges in the network for which the records are shorter. The exact mix between permanent and campaign GPS tide gauges will change as the cost of GPS receivers continues to decrease.

For studies involving sea level, it is recommended that a dual-frequency CGPS receiver should be installed directly at the tide gauge so that it monitors any movement of the TGBM. If the receiver is placed exactly at the TGBM, then the GPSBM and the TGBM will coincide, eliminating the need for levelling between the two benchmarks. The TGBM is then the fundamental point that is geocentrically located by the GPS measurements and to which all the sea level measurements are related. In practice, tide gauge sites are not always ideal for making GPS measurements. This may be due to obscured sky visibility, excessive multipath transmissions or because of radio interference, in which case a site should be chosen that is as close as possible to the tide gauge. Ideally, this should be within a few hundred metres.

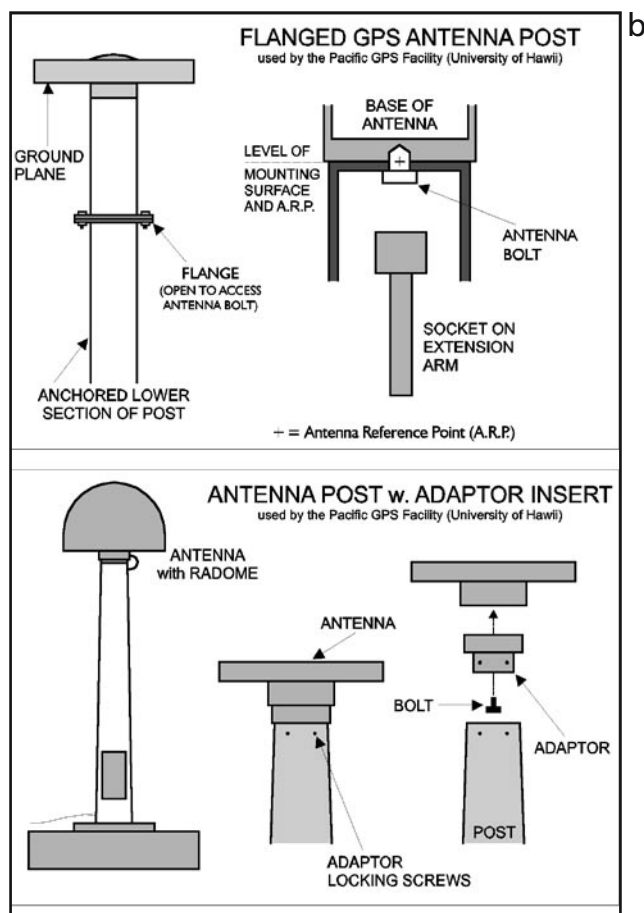

Figure 4.3 Alternative forms of GPS mounting (a) a Norwegian tide gauge with GPS antenna mounted on an adjacent platform; (b) GPS antenna on a pillar, as recommended by the CGPS@TG group (http://soest.hawaii.edu/cgps_tg).

The GPSBM and GPS antenna need to be levelled to the TGBM at least annually. Experience has shown that these regular levelling connections are often neglected over the years. This is particularly true if the distance involved is more than a few hundred metres and it can never be assumed that even relatively close sites are not moving differentially at a rate of around 1 mm per year.

Whilst the detailed procedures for making GPS measurements at tide gauges are still the subject of research, and are still being discussed by the IGS/PSMSL Technical Committee, there is already a general agreement on the main principles. Using GPS for measuring horizontal crustal movements is now well established. However, for the vertical component, measuring land movements to better than 1 mm per year is still a major challenge. Research is continuing on modelling the wet component of the troposphere, modelling the deformation of the Earth due to surface loading by ocean tides, coastal and global sea levels, atmospheric variations and hydrological loading. A major research challenge lies in realizing and maintaining a global reference frame that is sufficiently stable for measuring vertical movements to an accuracy of a few tenths of a millimetre per year (Teferle et al., 2006; Ge et al., 2005).

In some countries, a second CGPS receiver is being installed a few kilometres inland at a site which has a good multipath environment and a better connection to bedrock. While such a site might be better for testing geophysical models of vertical crustal movements, it cannot be considered to be a substitute for the CGPS receiver at the tide gauge. The difficulty and cost of levelling over distances of a few kilometres are significant.

Many of the practical issues involved with installing CGPS at tide gauges are reviewed in the case studies on the web site http://soest.hawaii.edu/cgps_tg and also in the associated paper by Bevis et al. (2002).

4.4.3 DORIS Measurements

DORIS is a French tracking system based on a space segment placed on an orbiting satellite and a network of ground stations distributed worldwide. Initially it was conceived to improve our knowledge of satellite orbits, but once these were determined to a sufficient accuracy, the system could be used to locate the geocentric position of the receiving antenna at each ground station.

DORIS is a one-way Doppler uplink system in which the ground stations broadcast continuously on two frequencies, 2 GHz and 400 MHz, in order to correct Doppler measurements for ionospheric delay. Each beacon includes an ultra-stable oscillator and meteorological sensors to correct the data for tropospheric delay. The space segment is made up of the set of satellites carrying the DORIS onboard receiver. Six DORIS receivers are currently work-

ing onboard the TOPEX–Poseidon, Jason, Envisat and the Earth observation satellites Spot-2, Spot-4 and Spot-5.

The DORIS technique has proved to be capable of monitoring vertical land movements with the following precision. In the early 1990s, when only one satellite was in orbit, the precision of absolute positioning was about 4 cm. This precision was regularly improved as new satellites were launched, and reached around 1.5 cm accuracy. The six satellites now in orbit provide sub-centimetre precision in absolute positioning, and vertical land velocities with a precision of 1 mm per year.

The current network of DORIS ground stations offers a homogeneous distribution over the continents and oceans, with about 60 beacons deployed in some 30 countries. It is planned to increase this distribution through the framework of the International DORIS Service. Some DORIS ground stations have been co-located at stations possessing other geodetic instrumentation. For example: 7 at Satellite Laser Ranging sites; 28 at GPS sites; 9 at VLBI sites; and 14 at tide gauges.

4.4.4 Absolute Gravity Measurements

The principle of the absolute gravimeter is the measurement of the acceleration of a mass in free fall (or rise and fall) in a vacuum using a laser length standard and a rubidium-frequency time standard. The mass used in the gravimeter is a retro-reflector that forms one end of a laser interferometer. By counting interference fringes as the mass falls, the position of the mass is measured and determined as a function of time. Considerable effort has been put into reducing or eliminating various sources of systematic error in the instrument. The latest transportable absolute gravimeter is the FG5 instrument (Niebauer et al. 1995). The specifications for this instrument are a precision of better than 1 mgal and an accuracy of 2 μ gal (N.B. 1 gal = 1 cm/sec², so 1 μ gal = 10 nm/sec². A microgal (mgal) corresponds roughly to 5 mm of crustal movement). For further details of the absolute gravimeter and a bibliography of published papers see the Micro-g website (<http://www.microgsolutions.com/>).

The gravity value at a site is found by making repeated drops of the test mass for typically one or two days and making corrections for the gravitational variations caused by tides, earth tides and atmospheric pressure. Various intercomparison experiments have been made between different FG5 absolute gravimeters; typically they agree at the 1–2 μ gal level (Sasagawa et al., 1995). At good sites, measurements made over a number of years show repeatability of about 2 μ gal.

In free air the gravity gradient at the Earth's surface, is 3 mgal/cm. In practice, for crustal deformation work, since a large area of the Earth's surface is usually displaced simultaneously, the measured gravity change is about 2 μ gal/cm. Thus, it can be seen that absolute

gravity and GPS are both approaching the equivalent accuracy of 1 cm that is required for measuring vertical crustal movements.

Absolute gravity measurements are normally made in a convenient building that provides reasonable temperature control. This site then needs to be connected to the TGBM and the local benchmarks using high precision levelling. Corrections for ocean tide loading and attraction are particularly important at or near coastal sites, as is the additional ocean tide attraction due to the elevation of the site.

Owing to the higher cost of absolute gravimeters compared to GPS receivers, the number of tide gauges being monitored is likely to be a small sub-set of the tide gauges with GPS. It has been recommended that the measurements of absolute gravity should be concentrated at key tide gauges in the GLOSS-LTT network, where they will be most useful in contributing to meeting the challenge of determining vertical crustal movements to an accuracy of better than 1 mm per year. Absolute gravity measurements at the GLOSS tide gauges at Newlyn and Lerwick have recently shown that there are systematic errors in CGPS, which lead to errors in the vertical rates determined from GPS (Teferle et al., 2006). This shows the importance

of independent techniques for identifying systematic errors and the reduction of these errors is currently an important topic of research in the GPS community.

4.4.5 Geocentric Co-ordinates and Vertical Land Movements of Tide Gauge Benchmarks

From 2001 to the end of 2005, the International GNSS Service (IGS) set up a pilot project called TIGA, which is processing and analysing CGPS data from over 100 tide gauges around the world in a consistent global reference frame. The web site (http://adsc.gfz-potsdam.de/tiga/index_TIGA.html) should be consulted for information about the stations and the results that are being obtained. The GPS global sea level monitoring network will be a fully integrated component of the International GNSS Service – International Earth Rotation Service (IGS/IERS) International Terrestrial Reference Frame (ITRF). The products from this network are the co-ordinates and velocities of the benchmarks at tide gauge stations. The Permanent Service for Mean Sea Level (PSMSL) archiving system has been designed to bank the vertical crustal velocities derived from selected IGS solutions, along with explanatory information, including the names of experts who can be contacted by users of the system.

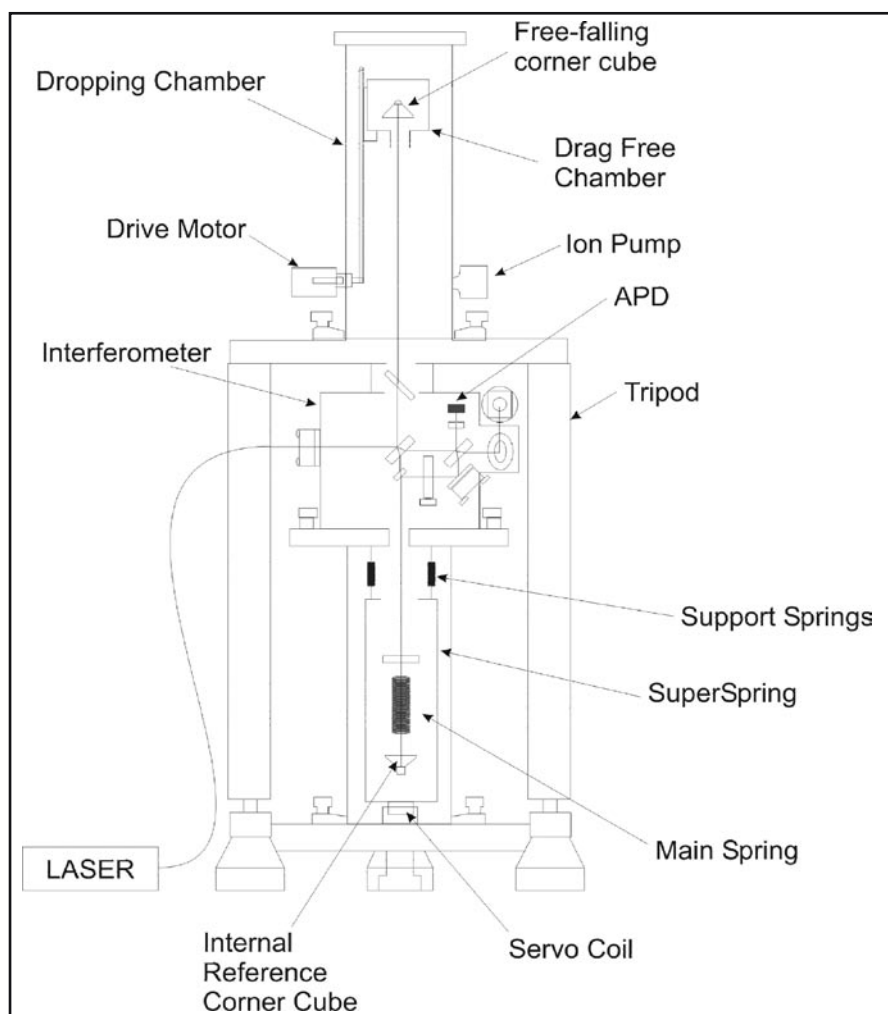

Figure 4.4 Schematic of an absolute gravimeter.

5. Real Time Data Transmission

5.1 Introduction

Sea level data acquired by a tide gauge may be required in 'real time', 'near real time' or in 'delayed mode' depending on the application. For example, a storm surge or tsunami warning system may require the data to be transmitted to the competent authorities in a very short time. On the other hand, for some scientific research, it is often only necessary to recover the data annually, in which case it can be stored locally and recovered during a site visit, either by downloading the data to a PC or by extracting and replacing a memory card. In any case, it is expedient to adopt such a local procedure, even if a communication link is in operation, to prevent loss of valuable data.

The method of communication depends largely on the distance the data have to be transmitted. For short links (e.g. harbour operations), a radio link is often convenient. For countrywide links, Subscriber Trunk Dialing or dedicated telephone lines of the Public Switched Telephone Network (PSTN) are an effective medium.

Where fixed lines are not practical, the growth in the use of Mobile Phone Links using General Switched Messaging (GSM) technology and General Packet Radio System (GPRS) protocols has extended the potential for long-distance communication. Both the fixed and mobile telephone systems give access to the Internet through an

Internet Service Provider (ISP) which can greatly enhance the transmission of data. For example, many of the GPS stations of the global network of the International GNSS Service, which has some similarities to the global tide gauge network in terms of number of sites and amount of data to be transmitted, report through the Internet. All the forms of telephony are merging into one, with telephone links provided by a supplier for which the connection method is transparent to the user. After the tsunami of 26 December 2004, India has implemented a real-time coastal sea level data transmission by means of GPRS with continuous connection to Internet, with much lower costs than previous experiments based on SMS and Data Call Services (Antony Joseph, personal communication).

For more remote areas, the use of mobile satellite links is an alternative. There are now upward of 30 orbiting satellite systems in operation dedicated to data transmission, some on a global basis. Mobile satellite systems (MSS) may be classified according to orbit altitude as follows:

GEO – geostationary earth orbit, approximate altitude: 35,000 km
 MEO – mid-altitude earth orbit, approximate altitude: 10,000 km
 LEO – low earth orbit, approximate altitude: <1,000 km

LEOs can be further sub-divided into Big LEO and Little LEO categories. Big LEOs will offer voice, fax, telex, paging and data capability, whereas little LEOs will offer data capability only, either on a real-time direct readout ('bent pipe') basis, or as a store-and-forward service. Since the satellite footprint decreases in size as the orbit gets lower, LEO and MEO systems require larger constellations than GEO satellites in order to achieve global coverage and avoid data delays. Lower power is, however, generally required for LEO and MEO satellite communication because of the shorter average distance between transmitter and satellite. Some systems implement several high-gain antennas to generate 'spot beams' and so reduce the requirement of the mobile to have a complex antenna and/or high output power. A key feature of several MSS currently under development will be their inter-operability with existing

public switched telephone and cellular networks, using a dual-mode handset.

From a technical point of view, some systems do offer significantly enhanced capabilities compared to existing methods. Potential advantages include two-way communication, more timely observations, and greater data rates and volumes. Some systems may also prove to be considerably less expensive than existing channels, although this is as yet unclear. Table 5.1 contains a list of the known satellite systems and their current status.

The Global Telecommunication System (GTS), hitherto used for the transmission of meteorological data and information also has its place in GLOSS and is therefore considered in a separate section (5.3.3).

Table 5.1 A list of the known satellite systems and their current status.

System	Status*	Orbit type	Message type	Terminal size		Comments
APRIZESAT	Operational	Little LEO	Data: TBD	Handheld	7	4 nanosatellites in orbit, 2-way communications, directed at asset tracking
ARGOS	Operational	Little LEO	Data: 32 bytes	Handheld	1	Various enhancements, including 2-way messaging, are scheduled
ECCO (CCI Global)	On hold	LEO	Voice/data	Handheld	TBD	12 equatorial satellites planned by 2003. Status questionable – merged with ICO-Teledesic Global
ELLIPSO	Licensed On hold	Big LEO	Voice/data	Handheld	TBD	17 satellites in highly elliptical orbits, serving major land masses. Status questionable – merged with ICO-Teledesic Global
EYESAT	Experimental	Little LEO	Data: 60 bytes	Handheld	5	1 satellite 1995, principally for radio amateurs
E-SAT	Licensed On hold	Little LEO	Data: TBD	TBD		6 satellites for utility metering (aimed at continental USA only initially)
FAISAT	Licensed On hold	Little LEO	Data: 128 bytes	Handheld	10	38 satellites 2000+ Test satellite launched 1997
GEMNET	Cancelled (pre-op)	Little LEO	Data: no maximum	Laptop	10	1st satellite 1995: launch failure 36 satellites by ???
GLOBAL STAR	Operational	Big LEO	Voice/data: no maximum	Handheld	1	48 satellites + spares (constellation complete); two-way (voice) and real-time transmission. Limited coverage due to lack of ground stations. Financial difficulties.
GOES, METEOSAT, MTSAT	Operational	GEO	Data: various options	Laptop	10	4 satellites; directional antenna desirable NOAA-ESA-MTSAT (Japanese meteorological) satellites.
GONETS-D	Pre-operational	Little LEO	Data	Handheld	TBD	8 satellites in orbit, 36 more planned

GONETS-R	Planned On hold?	Little LEO	Data	Handheld	TBD	48 satellites planned
INMARSAT-C	Operational	GEO	Data: no maximum	5.5 kg	15	Steered antenna not required
INMARSAT-D+	Operational	GEO	Data: 128 bytes uplink, 8 bytes downlink	Handheld	1	Global pager using existing INMARSAT-3 satellites. Note: very oriented to downlink
INMARSAT-BGAN	Operational	GEO	Broadband data: no maximum	Laptop	TBD	Two of three satellites currently in operation covering the Indian Ocean and the Atlantic; third satellite covering the Pacific due to be launched in 2007
ICO (New ICO)	Licensed On hold?	MEO	Voice/data: no maximum	Handheld	1	Global voice and packet data services. Recently merged with Teledesic to form ICO Teledesic Global. 12 satellites planned, only one launched so far
IRIDIUM	Revived	Big LEO	Voice/data: no maximum	Handheld	1	72 satellites in orbit; offers true global coverage; two-way (voice) and real-time transmission
IRIS/LLMS	Experimental On hold	Little LEO	Data: up to few kbytes	Handheld	1	1 satellite in orbit. Belgian messaging system part of an ESA research programme
LEO One	Licensed On hold	Little LEO	Data: uplink 9,600 bps, downlink 2,400 bps	Handheld	Max 7	48-satellite constellation, store and forward + 8 spares. No polar satellites
LEO SAT Courier	Planned On hold?	Big LEO	Data/voice	Handheld	1-5	72 satellites
OCEAN-NET	Experimental	GEO	No maximum	Large		Uses moored buoys + Intelsat
ODL (Ocean Data Link)	Experimental On hold?	GEO	No maximum	Handheld	TBD	Uses Intelsat
ODYSSEY ORBCOMM	Cancelled (pre-op)	MEO	Voice/data: no maximum	Handheld	1	12 satellites were planned
	Operational	Little LEO	Data: no maximum	Handheld	5	35 satellites in orbit; 30 operational; expansion to 48 licensed; e-mails (Globalgrams) to subscriber network
SAFIR	Pre-operational On hold	Little LEO	Data: no maximum	Laptop	5	2 satellites in orbit
SIGNAL	Planned On hold?	Big LEO	Voice/data			48 satellites planned
SKY BRIDGE	Licensed On hold	Big LEO	Broadband	Larger than handheld		80 satellites planned, recycling GEO spectrum allocations

STARSYS	Cancelled (pre-op)	Little LEO	Data: 27 bytes multiple messages	Handheld	2	12 satellites 1998+ 24 satellites 2000+
TELEDESIC	Licensed On hold	Big LEO	Broadband			288 LEOs planned, now reduced to 30 MEOs FCC licence granted, merged with new ICO
TEMISAT	Experimental	Little LEO	Data			7 satellites planned for environmental data relay. 1 satellite launched 1993.
THURAYA	Operational	GEO	Voice/data	Handheld		1 multiple-spot beam satellite in orbit (over Middle East); 1 planned
VITASAT	Pre-operational	Little LEO	Data			2 satellites in orbit, 2 more planned
VSAT	Pre-operational	Little LEO	Data			2 satellites in orbit, 2 more planned
WEST	Planned On hold	MEO	Broadband			9 satellites planned

The status of each system in Table 5.1 is categorized according to seven groups:

- **Planned:** Little is known about the system, except a name, notional type, and services to be offered. Mostly not licensed, although some may be.
- **Licensed:** System has been licensed by a national or international regulatory agency (in most cases the FCC), but no satellites have been launched.
- **Experimental:** System has one or more satellites in orbit for experimental purposes (not usually part of the final constellation). Includes new systems planning to use existing satellites.
- **Pre-operational:** System is in process of launching, or has launched, its constellation, but is not yet offering full services. Some limited evaluation service may be available.
- **Operational:** System has full or nearly full constellation in place and is offering readily available service to external users (not necessarily commercial).
- **Cancelled:** System has been cancelled, either before satellites launched (pre-op.) or after (post-op.).
- **On hold:** No progress reported or scheduled.

5.2 Choice of a System

Selection of a communication system for sensor real-time (RT) or near-real-time (NRT) data transmission is always a compromise among a number of constraints. The principal factors guiding decision in the adoption of a system are:

- data rate, data-rate profile in different operational modes (if more than one)

- power availability (power from mains or autonomous/self-powered)
- guarantee of data transmission (private network or shared data line)
- location, availability of telecommunication infrastructure (satellites in field of view)
- land or marine application (fixed or moving)
- availability of funding.

Satellite communication systems at data-transmission rates of kbits/s and Mbits/s are operating in the L-band (1–2 GHz), the C-band (4–8 GHz) or the Ku (10–18 GHz)/Ka(18–40 GHz) band.

For marine applications, L-band systems are currently the best choice. Satellite cell phones are operating typically in the L-band and may be used for data transfer needs of a few kbits/s. The data-transmission rate on the L-band is much more bandwidth-limited, but some systems allow for more than 100kbits/s. Antenna directionality is less critical and even non-directional antennas with sufficient beam width (eg +/-60°) are workable, though at lower data-transmission rates (i.e. from a few kbits/s to some 10 kbits/s).

The higher the frequency the easier it is to transmit large data sets at reasonable antenna sizes. However, attenuation by rain is stronger at higher frequencies, therefore Ka transmission from space has so far not been very common. Ku has also hitherto been less favoured in countries with heavy rainfall, but is becoming more used nowadays.

One of the key issues with any communication system involving data is the data capacity. Many satellite sys-

tems have a limited capacity during any one transmission. Telephone links, by and large, have an adequate bandwidth for most foreseeable applications, especially with the new ADSL–Broadband facilities that are being introduced. The latter may be somewhat limited in its spatial coverage at present, but it is fair to say that the communications industry is one of the fastest growing areas of commercial activity and consequently coverage may be greatly increased in the foreseeable future.

Two-way communications with a tide gauge can be advantageous. It can be used to update software or calibration values at the station, to interrogate the system for faults, to change the sampling rate and to carry out many house-keeping functions that would otherwise wait for a site visit. This allows the system to be flexible and improves overall reliability.

In adopting a communication system for a tide gauge installation, one consideration has to be its reliability under severe environmental conditions. For example, for tsunami warning, some of the tide gauges may have to be positioned in a tectonically active region to provide an acceptable early warning. In the event of an earthquake, the first losses are often the PSTN network, mobile telephone links as well as electrical power. Under such circumstances, satellite links may be the only option. Additionally, some form of uninterruptible power supply (UPS) is necessary. This often takes the form of a battery back-up system with an adequate reserve capacity of several hours.

A number of manufacturers, including tide gauge and data logger manufacturers, produce relatively inexpensive ready-to-use communications systems suitable for tide gauges. For a list, see the websites given on the PSMSL website: <http://www.pol.ac.uk/psmsl>.

5.3 Data Transmission Systems

For the last decade or more, tide gauge installations have used the satellite systems of ARGOS, GOES, Meteosat, MTSAT and INMARSAT for data transmission. More recently, other, newer possibilities are being exploited or considered for exploitation: GLOBALSTAR, INMARSAT/BGAN, IRIDIUM, ORBCOMM and VSAT. Characteristics of each system in terms of the cost of hardware, bandwidth and latitude coverage differ significantly.

5.3.1 Systems already well established

ARGOS (www.argos-system.org) operates worldwide using polar orbiting satellites with an orbital period of about 100 minutes. A platform transmitter terminal (PTT), with a data bandwidth capacity of 256 bits per satellite pass, is located at the gauge and,

depending on location, the delay in data reception by the user may be several hours. Data are available to users through the Argos Global Processing Centres at Toulouse, France, and Largo, Fla., USA. The number of accessible satellite passes per day is latitude-dependent, varying from about 7 at the equator to 28 at the poles. Users of ARGOS for tide gauge data acquisition include GRGS in France which will be able to provide advice to potential users.

GOES-E (USA), GOES-W (USA) (www.goes.noaa.gov/), METEOSAT (Europe) (www.esa.int/SPECIALS/MSG/; www.cnes.fr/), and MTSAT (Japan) (www.fas.org/spp/guide/japan/earth/gms/) form a network of geostationary satellites offering overlapping longitudinal coverage. Latitude cover is limited to about 75° because of their equatorial orbit position. Each data collection platform (DCP) located at the gauge is allocated fixed time slots during which 649 bytes of data can be transmitted to a satellite. Up to one time slot every six minutes can be allocated to each DCP, so that, if necessary, data could be available to users within this time frame. Previous problems with clock drift have been eliminated by including GPS receivers in each DCP. Users of these systems include POL in the UK and NOAA and the University of Hawaii Sea Level Center in the USA. Data sent via the geostationary meteorological satellites (GOES, Meteosat, MTSAT) is usually passed on to the Global Telecommunication System (GTS) of the WMO (see section 5.3.3 & 5.3.4). Information about how to apply for DCP transmission slots can be found at:
GOES: <http://noaasis.noaa.gov/DCS/>
METEOSAT: <http://www.eumetsat.int/>
MTSAT: <http://www.jma.go.jp/jma/jma-eng/satellite/dcs.html>.

INMARSAT Standard-C (www.inmarsat.com) also uses a network of geostationary satellites giving worldwide coverage except for latitudes above 75°. This system allows two-way data communication in near real time at a rate of 600 bits/s, with a data message up to about 8 kbytes. Tide gauge users of INMARSAT in the past include the Australian Hydrographic Service.

5.3.2 Systems now being applied or considered for application in the transmission of sea level data

There has been a major increase in the uptake of broadband services globally and more specifically at even remote islands that form the basis of POL's sea level measurement network in the South Atlantic. POL has sites at Ascension Island, St. Helena Island, the Falkland Islands and Tristan da Cunha. Leased lines, offering continuous, high-speed internet access are available on all these islands except Tristan da Cunha.

POL has developed instrumentation that can take the output from a range of sensors, including radar and

pressure types. The data are collected by a small Linux-embedded processor and sent back to base by e-mail or by secure copy protocol (SCP). Broadband-enabled test sites using a radar sensor connected to an embedded Linux system have been installed at Liverpool and Holyhead in the UK. One-minute data values are available every five minutes in the form of an e-mail message. The resulting data are displayed on the NTSLF web pages: <http://www.pol.ac.uk/ntslf/networks.html>. Over the last 6 years the Spanish Ports Authority (Puertos del Estado) has also been using e-mail/ftp data transmission from harbour gauges to a PC. Future sea level stations will communicate via embedded Linux-based systems instead of Windows based PCs.

The advantages of broadband technology are:

- Continuous two-way connection allowing high-speed data sampling and near-real-time data retrieval. Remote gauge diagnostics are available and the ability to re-programme the system remotely.
- Timing drift and operator setup error eliminated by having accurate time available from network time protocol (NTP) servers on the internet.
- Data delivery costs are known up-front, because the subscription costs are paid monthly or yearly.
- Real-time data collection allows malfunctions to be found and fixed, more rapidly.
- Fixed-line broadband systems can also allow backup access through a dial-up modem.

The disadvantages of broadband technology are:

- A LAN interface is required; this is often difficult to add to existing tide gauge systems. A land line is necessary for non-satellite broadband systems.
- Serial port is generally not available, so interfacing is more difficult.
- Power requirement for broadband modems is quite high (~1 amp), this can create problems where mains power is not available.

The following list provides a summary of satellite systems/services that are being applied or considered for application by some members of the sea level and geodetic community for the transmission of sea level and GPS data:

The INMARSAT/BGAN (Broadband Global Area Network) service (www.inmarsat.com) began with the launch of F1 and F2 INMARSAT-4 (at 64°E and 53°W respectively) in 2005. These satellites cover Europe, Africa, Asia (partly) and Americas and will eventually be joined by a third satellite, F3 I-4 (178°E) to give virtually full world coverage. Presently, broadband speed of 492 kbits/s is available with a static IP address. Connection is by LAN, USB or Bluetooth; there is no serial port connection. Instruments interfaced to this terminal unit will need a network connection.

BGAN is a drop-in replacement for land-line broadband modems. It shares most of the advantages and disadvantages of conventional broadband, but is capable of operating in remote areas and is optimized for low-power operation. BGAN's biggest advantage over fixed-line broadband is its independence of local telephone infrastructure, and during extreme conditions it will most likely continue operating.

GLOBALSTAR (www.globalstar.com/en/works/ and www.globalstar.com/en/contact.php) is a commercial global satellite telephone service based on 40 LEO satellites. The network is capable of picking up signals from over 80% of Earth's surface outside extreme polar regions and some mid-ocean regions. The system offers voice and data transmission via a secure code division multiple-access (CDMA) satellite signal; there is no perceptible voice delay. There is sufficient back-up in the system to prevent call interruption. Signals are distributed to existing fixed or local cellular-phone networks in over 120 countries.

IRIDIUM (www.iridium.com; and www.deltawavecomm.com which is a service provider for Iridium and other systems) is a similar type of system to that of Globalstar, but claims 'complete coverage (including oceans, airways and polar regions)'. It comprises a 'fleet' of 66 LEO satellites operating in a fully-meshed network. It serves a wide range of commercial, governmental and social sectors and designs and sells its own equipment through a world-wide network of more than 100 partners. Iridium specifically offers data-transmission services via laptop and cellphone world-wide, including very remote areas.

ORBCOMM (www.orbcomm.com) consists of a space segment of 36 LEO satellites with ground segments called Gateway Earth Stations (GES) and Gateway Control Centres (GCC). From some areas communications can be in near-real time. However, where a receiving satellite cannot communicate with a GES and a subscriber simultaneously, ORBCOMM operates in Globalgram mode. In this mode the subscriber data are relayed through a GES and GCC to an Internet Service Provider and there may be a delay of several hours in receiving data. For much of Africa and the Indian Ocean, the Globalgram mode is the only option.

VSAT (Very Small Aperture Terminal) (www.vsat-systems.com) satellite terminals are commonly used by the geodetic community for communication at remote locations and via GPS stations co-located with tide gauges; they are available for use in the C, Ka and Ku bands. Data-transmission rates are up to several Mbits/s per terminal. For smaller data-transmission rates, VSATs are clustered in a network with a central hub for network control. In that way, the system capacity can be shared among various users (terminals). For VSAT systems, TDMA (time-division multiple access) is probably the most common technique to share a common transmission source among a num-

ber of individual users. TDMA technology is relatively simple: small complexity in receivers and allocation of the whole frequency (bandwidth) to each user, but only on a part-time basis. The information for different users is transferred sequentially in "bursts". Disadvantages are the need for network-wide synchronization and related overheads/inefficiency in bandwidth use. VSAT terminals each require a relatively precise antenna pointing to the satellite and can only be used from solid ground. Power consumption is typically above 50 W.

5.3.3 The Global Telecommunications System (GTS)

The GTS (www.wmo.ch/web/www/TEM/gts.html; www.wmo.ch/web/www/ois/Operational_Information/WMO386/ManOnGTS.html, which is the GTS Manual) is widely used by all the meteorological organizations for real-time transmission and interchange of environmental data; up to now, however, it has not been used much by the sea level community. This situation is changing, given the development by the IOC of an Indian Ocean Tsunami Warning and Mitigation System, and that can be thought of as a possible future for the GLOSS network, and in particular for the GLOSS Fast Data Centre (GFDC). For the development of the Indian Ocean tsunami warning system, it has been decided that data have to be transmitted within 15 minutes of

being recorded at a tide gauge. (A 1-minute average, 5 minute cycle may be adapted for selected sites close to tsunamigenic source areas). The data would be composed of 1-minute averages to achieve the required resolution and would need to be made available on the GTS. This is in fact the actual recommendation for sea level data transmitted for tsunami warning systems: making use of the GTS, which works well if geostationary meteorological satellites are used for data transmission. If this is not the case, arrangements with the national meteorological organizations may be needed for including and downloading sea level data from the GTS; automatic transmission by e-mail or FTP will probably be required from the national sea level agency to the meteorological institute, GFDC or Tsunami Alert System, for including the data in GTS.

5.4 Data Transmission Formats

To the extent that the GTS is retained as the preferred means of transmitting tide gauge data from their source (the gauges) to the concerned data centres (notably, PSMSL, UHSLC and national sea level data centres, the necessary data format is contained in the WMO Manual on Codes (www.wmo.int/www/WMOCodes/ManualCodes/WMO306.html).

6. Quality Control of Data

Data recovered from a tide gauge always provide time-series with a particular sampling interval. Even analogue charts are digitized to provide levels at regular points in time. Until recently, most data acquired this way have been archived and distributed by data assembly centres (DACs) in a quality controlled (QC) and fully documented form. This results in 'delayed mode' data sets. Volume 3 and earlier editions of this Manual dwelt at length on QC of data in delayed mode. Such QC methods are well established and will not be repeated here.

However, sea level data are required for many purposes, and in many applications there is no time to perform a full QC. For example, during the World Ocean Circulation Experiment (WOCE), the University of Hawaii Sea-Level Centre (UHSLC) was established as the 'fast delivery' DAC, with the British Oceanographic Data Centre (BODC) as the 'delayed mode' WOCE DAC. The UHSLC was tasked with the assembly, quality control and distribution of sea level data from WOCE gauges within several weeks, comparable to the delay, at the time, in the delivery of satellite altimeter data. Meanwhile, BODC had the task to assemble and supply sea level data from the WOCE network to the full extent of quality control within 18–24 months from data collection.

More recently, there has been an emphasis on making as many GLOSS gauges as possible deliver data in near-real time, i.e. typically within an hour. This

requirement has arisen for several reasons. First, with real-time data, it is immediately obvious when problems with a gauge have occurred. Second, the data become available for many other applications within 'operational oceanography', e.g. for flood warning or for assimilation of sea level data into ocean circulation models. The data are also then useful for tsunami warning systems in certain areas. The GLOSS programme has defined the UHSLC as the 'GLOSS Real-Time Centre' in addition to the existing 'Fast Centre' responsible for producing hourly values for monitoring and models.

If sea level data are used in near-real-time applications, then the operational system has to be robust enough not to be perturbed when bad data are recorded (e.g. data spikes). One way to guard against bad data is to have continuous human oversight of the data stream (e.g. as occurs in the UK Storm Tide Forecasting Service for flood warning). Real-time quality control (RTQC) software is now being developed by several groups. For example, in Europe the Spanish Ports Authority (Puertos del Estado) has developed an automatic quality control of sea level data for detection of spikes, gaps, etc. before data is displayed on the public web-page and assimilated into a storm surge forecasting system. Information about this software and the algorithms for spike detection can be obtained from Begoña Pérez.

7. Training Materials and Contacts

The PSMSL maintains web pages (www.pol.ac.uk/psmsl/training/) that provide access to training materials developed both by itself and by other agencies, primarily as part of GLOSS development. These materials include:

- Reading list (1) Books on tides and sea levels, including IPCC Reports
- Reading list (2) Geodesy, GPS and other useful information
- Reading list (3) Satellite altimetry information
- Reading list (4) Further reading on the Web
- Manuals, including the IOC tide gauge training manuals, the present volume included
- Powerpoint files
- Brochures in various languages
- Descriptive overviews of sea level recording in each country or region
- Publications relevant to the PSMSL and GLOSS
- GLOSS demonstration CD contents, January 2005
- Training courses organized by IOC/GLOSS and other organizations
- Tidal analysis and prediction packages
- Cross-wavelet and wavelet-coherence software
- A list of tide gauge manufacturers and suppliers
- Tide gauge experiences

Technical experts who may be asked to provide advice on tide gauges and related topics are shown on the following page.

In addition, the PSMSL provides a set of useful contacts in each country (http://www.pol.ac.uk/psmsl/sea_level_contacts.html). Such contact information becomes out-of-date rapidly and the PSMSL would be grateful to know of errors and omissions (via psmsl@pol.ac.uk).

Acoustic Gauges with Sounding Tube	Allan Suskin, NTF Australia. allan@pacific.ntf.flinders.edu.au Bernie Kilonsky, UHSLC, USA kilonsky@soest.hawaii.edu
Acoustic Gauges without Sounding Tube (SRD)	Begoña Pérez Gómez, Puertos del Estado, Spain bego@puertos.es Ruth Farre hydrosan@iafrica.com
Single-Transducer Systems	Dov Rosen, NIO Israel rosen@ocean.org.il Peter Foden, POL UK prf@pol.ac.uk
Multiple-Transducer Systems ('B' gauges)	Peter Foden, POL UK prf@pol.ac.uk
Pressure Transducers in Stilling Wells	As for other pressure systems
Bubbler Pressure Gauges	David Smith, POL UK des@pol.ac.uk
Bottom-Mounted Pressure Gauges	Peter Foden, POL UK prf@pol.ac.uk
Float Gauges in Stilling Wells	Mark Merrifield, UHSLC USA markm@soest.hawaii.edu
Optical Shaft Encoders (especially for river and lake records)	Dave Johnstone, NIWA NZ d.johnstone@niwa.cri.nz
Radar Tide Gauges	Peter Foden, POL prf@pol.ac.uk Begoña Pérez, Puertos del Estado, bego@puertos.es
Advice on Data-Transmission Methods	David Meldrum, SAMS UK d.meldrum@sams.ac.uk
Advice on Geodetic Methods:	
GPS	Mike Bevis, Ohio State University, USA mbevis@osu.edu
DORIS	Anny Cazenave, GRGS, France anny.cazenave@cnes.fr
Absolute Gravity	Simon Williams, POL UK sdwil@pol.ac.uk

8. New Techniques for Sea Level Measurements

8.1 GPS on Buoys

Radar altimetry is widely used for various sea-level-related research. Owing to unknown post-launch biases and the aging of satellite electronic system components, a consistent and long-term stable offshore height reference is needed. Some satellites are passing offshore oil rigs equipped with tide gauges and GPS. However, these locations are rare. With the increasing accuracy of GPS for offshore applications, various groups have developed GPS-equipped buoys for the determination of the instantaneous sea-surface heights (iSSH). While in the past only a few calibration experiments were carried out for radar altimetry, in 2001 GPS buoys were successfully used during the calibration/validation campaigns of Jason-1 and ENVISAT. More recent applications are for tsunami detection (e.g. Kato et al. 2005).

One of the earlier calibration experiments was successfully carried out by Hein (Hein et al. 1990). Between 1999 and 2003, GPS water level measurement was coordinated by a special study group of the International Association of Geodesy (see http://www.gfz-potsdam.de/pb1/op/altimetry/SSG_buoys/index.html and references herein).

Depending on the type of application, logistic requirements, and sea state, different types of buoys are used.

The most simple and straightforward types are lifesaver-type buoys fitted directly with a GPS antenna (Watson et al., 2004; Figure 8.1), and towed by, for example, a vessel. Larger buoys, such as toroid buoys (Schöne et al., 2001; Figure 8.3) or barrel buoys, can be moored for long-term applications, but are in need of additional sensors to account for the buoy movement. Examples of height time-series from GPS buoys are shown in Figures 8.2 and 8.4.

To estimate the iSSH, GPS measurements are used in a differential mode. The computed value is further corrected for the dipping and the tilting of the buoy. The accuracy of GPS for the height component is better than a few centimetres, allowing very precise measurements of the iSSH. Even with a decrease in accuracy with increasing distance from the GPS reference station at the shore, the resulting iSSH values are precise enough for calibrating radar altimeters.

With the technological advances in hardware and new developments in GPS processing, small lightweight systems will be available to support the massive application in different fields. Fields of future research are the application of precise point positioning techniques to reduce the amount of data to be transferred, low-power consumption equipment, and new data transfer techniques for offshore applications.

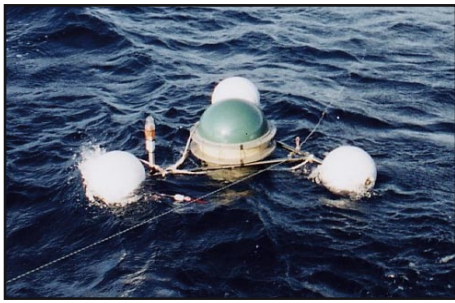

Figure 8.1 The University of Tasmania GPS buoy (C. Watson, personal communication).



Figure 8.3 The GFZ Potsdam GPS buoy.

8.2 GNSS Reflectometry

Once the European satellite constellation GALILEO starts transmission of navigation signals in 2008, an infrastructure of three global satellite navigation systems will be available for commercial and scientific applications. GALILEO, together with the US Global Positioning System (GPS) and the Russian GLONASS (Global'naya Navigatsionnaya Sputnikovaya Sistema) constellation, offers novel opportunities for remotely sensing the Earth's atmosphere and oceans with dense spatial and temporal coverage.

The high reflectivity of GPS signals in the L-band frequency range (1.2276 and 1.57542 GHz) at water and ice- or snow-covered surfaces allows for the detection and analysis of reflected GNSS (Global Navigation Satellite System) signals. The passive reflectometry and interferometry system (PARIS) was the first concept proposed for ocean altimetry using GNSS (Martín-Neira, 1993). In the

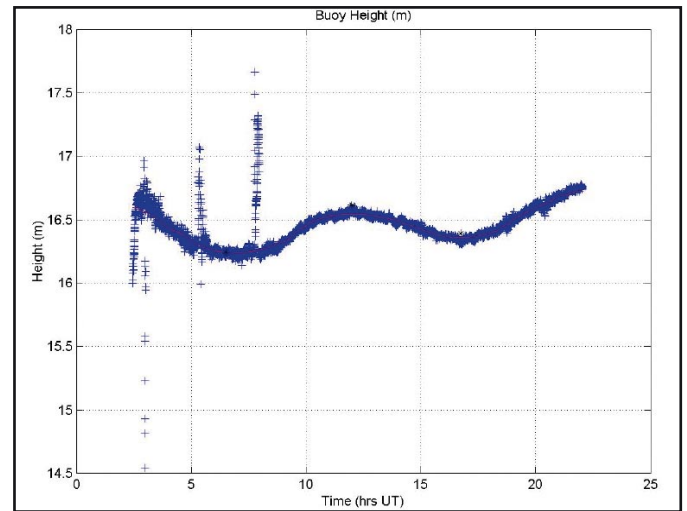

Figure 8.2 Height time-series (SSG 2.194, 2003).

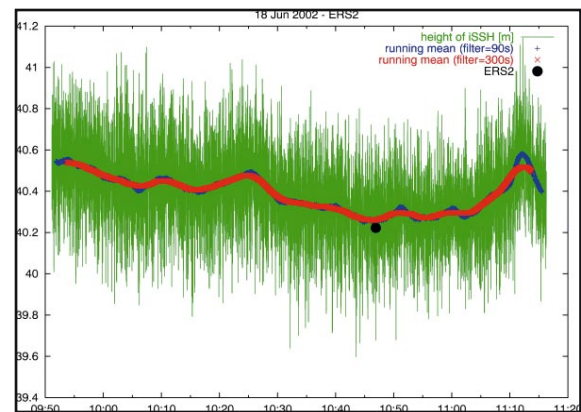

Figure 8.4 Height time-series from a GPS buoy; the time-series is dominated by sea state. The smoothed curves are the running mean filtered time-series; the dot is the actual RA measurement used for comparison.

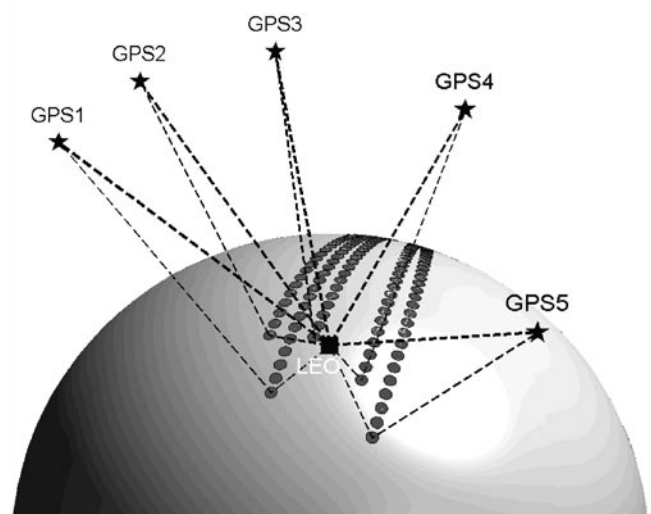

Figure 8.5 The PARIS concept.

PARIS scheme, direct and ocean-reflected signals are detected by spaceborne receivers, and altimetric height information is extracted from the delay in arrival times of the reflected signals relative to the direct signals (Figure 8.5).

Using dedicated GNSS receiver instruments, sea level heights accurate up to ~5 cm were determined in a number of airplane and balloon experiments (Garrison and Katzberg, 2000; Rius et al., 2002; Ruffini et al., 2004). In ground-based GNSS reflection experiments above an artificial pond, Martín-Neira et al. (2002) achieved an accuracy of 1 cm, and at an altitude of about 500 m above Crater Lake (Oregon, USA) altimetric height values accurate to 2 cm were obtained (Treuhaft et al., 2001). Anderson (2000) reported on 12-cm accuracy in near-surface measurements at heights between 7 and 10 m. In addition, the dependency of the code

correlation function on the slope characteristics of the reflecting surface can be used to infer sea-surface roughness as well as wind speed and direction (GNSS scatterometry) (Katzberg et al., 2001; Cardellach et al., 2003; Germain et al., 2004).

First spaceborne observations of signal reflections are described by Pavelyev et al. (1996) and Lowe et al. (2002); later, signatures of coherent GPS reflections at grazing incidence angles were found in radio occultation data observed by the GPS/MET, CHAMP and SAC-C satellites (Beyerle et al., 2002; Hajj et al., 2004). CHAMP and SAC-C are both already supplied with nadir-looking antennas to detect reflected GPS signals; efforts are now being made to establish space-based GNSS altimetry as a viable remote-sensing technique (e.g. Hajj and Zuffada, 2003).

References

This list contains references of interest to particular sections of the Manual, which may be used as further sources of information for that section. Some references are referred to explicitly in the text, while others are not. Some references appear in more than one section.

Section 2.1

IOC, 1990. Global Sea Level Observing System (GLOSS) Implementation Plan. Intergovernmental Oceanographic Commission, Technical Series No. 35, 90pp.

Section 2.2

Vassie, J.M., Woodworth, P.L. and Holt, M.W., 2004. An example of North Atlantic deep ocean swell impacting Ascension and St. Helena islands in the central South Atlantic. *Journal of Atmospheric and Oceanic Technology*, 21(7), 1095-1103.

Section 2.3

Pugh, D.T., 2004. Changing sea levels. Effects of tides, weather and climate. Cambridge: Cambridge University Press, 280pp.

Woodworth, P.L., Pugh, D.T., Meredith, M.P. and Blackman, D.L., 2005. Sea level changes at Port Stanley, Falkland Islands. *Journal of Geophysical Research*, Vol. 110, C06013, doi:10.1029/2004JC002648.

Section 2.4

Cartwright, D.E., 1999. Tides - a scientific history. Cambridge: Cambridge University Press, 292pp.

Cartwright, D.E., Edden, A.C., Spencer, R. and Vassie, J.M., 1980. The tides of the northeast Atlantic Ocean. *Philosophical Transactions of the Royal Society of London*. A 298, 87-139.

Doodson, A.T. and Warburg, H.D., 1941. Admiralty manual of tides. Her Majesty's Stationery Office, London.

Filloux, J.H., 1980. Pressure fluctuations on the open ocean floor over a broad frequency range. *Journal of Physical Oceanography*. 10(12) 1959-1971.

Forrester, W.D., 1983. Canadian Tidal Manual. Department of Fisheries and Oceans, Ottawa, 138pp.

Open University, 1989. Waves, Tides and Shallow-Water Processes. Open University Oceanography Series Vol.4. Oxford: Pergamon Press in association with the Open University, 187pp.

Pugh, D.T., 1987. Tides, Surges and Mean Sea level: a handbook for engineers and scientists. Chichester: Wiley, 472pp.

Pugh, D.T., 2004. Changing sea levels. Effects of tides, weather and climate. Cambridge: Cambridge University Press, 280pp.

Shum, C.K., Woodworth, P.L., Andersen, O.B., Egbert, G., Francis, O., King, C., Klosko, S., Le Provost, C., Li, X., Molines, J-M., Parke, M., Ray, R., Schlax, M., Stammer, D., Tierney, C., Vincent, P. and Wunsch, C., 1997. Accuracy assessment of recent ocean tide models. *Journal of Geophysical Research*, 102(C11), 25173-25194.

Spencer, R. and Vassie, J.M., 1997. The evolution of deep ocean pressure measurements in the U.K. *Progress in Oceanography*, 40, 423-435.

Section 2.4.1

Caldwell, P.C., 1991. Sea Level Data Processing Software on IBM PC Compatible Microcomputers. TOGA Sea Level Centre, University of Hawaii.

Doodson, A.T., 1928. The analysis of tidal observations. *Philosophical Transactions of the Royal Society*, A, 227, 223-279.

FIAMS, 1990. Tidal Time-Series Software Designed for use on a Personal Computer. FIAMS Tidal Laboratory. The Flinders University of South Australia.

Foreman, M., 1997. Manual for tidal height analysis and prediction. Institute of Ocean Sciences, Patricia Bay, Victoria, British Columbia. Pacific Marine Science Report 77-10. (Unpublished Manuscript).

Munk, W.H. and Cartwright, D.E., 1966. Tidal spectroscopy and predictions. *Philosophical Transactions of the Royal Society*, A, 259, 533-581.

Murray, M.T., 1963. Tidal analysis with an electronic digital computer. *Cahiers Oceanographique*. 699-711.

Section 2.5

Alvarez Fanjul, E., Pérez, B., and Rodríguez, I., 2001. Nivmar: a storm surge forecasting system for Spanish Waters. *Scientia Marina*, 65, 145-154.

Flather, R.A., 1984. A numerical model investigation of the storm surge of 31 January and 1 February 1953 in the North Sea. *Quarterly Journal of the Royal Meteorological Society*, 110, 591-612.

Flather, R.A., 2000. Existing operational oceanography. *Coastal Engineering*, 41(1-3), 13-40.

Rossiter, J.R., 1954. The North Sea storm surge of 31 January and 1 February, 1953. *Philosophical Transactions of the Royal Society*, A, 246, 371-400.

Wolf, J. and Flather, R.A., 2005. Modelling waves and surges during the 1953 storm. *Philosophical Transactions of the Royal Society*, 363, 1359-1375.

Section 2.6

Bryant, E., 2001. Tsunami: the underrated hazard. Cambridge University Press.

Leonard, M. 2006. Analysis of tide gauge records from the December 2004 Indian Ocean Tsunami. *Geophysical Research Letters*, 33, L17602, doi:10.1029/2006GL026552.

Merrifield, M.A., Firing, Y.L., Aarup, T., Agricole, W., Brundrit, G., Chang-Seng, D., Farre, R., Kilonsky, B., Knight, W., Kong, L., Magori, C., Manurung, P., McCreery, C., Mitchell, W., Pillay, S., Schindele, F.,

Shillington, F., Testut, L., Wijeratne, E.M.S., Caldwell, P., Jardin, J., Nakahara, S., Porter, F.-Y. and Turetsky, N., 2005. Tide gauge observations of the Indian Ocean tsunami, 26 December, 2004. *Geophysical Research Letters*, 32, L09603, doi: 10.1029/2005GL022610.

Section 2.7

Church, J.A., Gregory, J.M., Huybrechts, P., Kuhn, M., Lambeck, K., Nhuan, M.T., Qin, D. and Woodworth, P.L., 2001. Changes in sea level. In *Climate Change, 2001: The Scientific Basis. Contribution of Working Group I to the Third Assessment Report of the Intergovernmental Panel on Climate Change*. (eds. Houghton J.T., Ding Y., Griggs D.J., Noguer M., van der Linden P.J., Dai X., Maskell K. and Johnson C.A.). Cambridge: Cambridge University Press, 881pp.

Woodworth, P.L. and Player, R., 2003. The Permanent Service for Mean Sea Level: an update to the 21st century. *Journal of Coastal Research*, 19, 287-295.

Woodworth, P.L., Gregory, J.M. and Nicholls, R.J., 2004. Long term sea level changes and their impacts. pp.717-752 (chapter 18) in *The Sea, Volume 13*, edited by A.R. Robinson, J. McCarthy and B.J. Rothschild. Harvard University Press.

Section 2.8

Hamon, B.V. and Middleton J.F., 1989. Return periods of extreme sea levels: the exceedance probability method. *International Hydrographic Review*, LXVI(2), 165-177.

Lennon, G.W., 1963. A frequency investigation of abnormally high tidal levels at certain west coast ports. *Proceedings of the Institution of Civil Engineers*, 425, 451-484.

Middleton, J.F. and Thompson, K.R., 1986. Return periods of extreme sea levels from short records. *Journal of Geophysical Research*, 491, 11707-11716.

Pugh, D.T. and Vassie, J.M., 1979. Extreme sea levels from tide and surge probability. *Proceedings 16th Coastal Engineering Conference, 1978, Hamburg*. American Society of Civil Engineers, New York, 41, 911-930.

Smith, R.L., 1986. Extreme value theory based on the r largest annual events. *Journal of Hydrology*, 486, 27-43.

Suthons, C.T., 1963. Frequency of occurrence of abnormally high sea levels on the east and south coasts of England. *Proceedings of the Institution of Civil Engineers*, 425, 443-449.

Tawn, J.A. and Vassie, J.M., 1989. Extreme sea levels: the joint probabilities method revisited and revised. *Proceedings of the Institution of Civil Engineers, Part 2*, 87, 429-442.

Tawn, J.A., 1992. Estimating probabilities of extreme sea levels. *Applied Statistics*, 41, 77-93.

Section 3.1

IOC, 2004. New technical developments in sea and land level observing systems. *Proceedings of meeting October 14-16 2003, Paris, France*. IOC Workshop Report No 193. 174pp & Annexes.

Section 3.1.1

Pugh, D.T., 1987. *Tides, Surges and Mean Sea level: a handbook for engineers and scientists*. Chichester: Wiley, 472pp.

Section 3.2

IOC, 1985. *Manual on Sea level Measurement and Interpretation. Volume 1 - Basic procedures*. Intergovernmental Oceanographic Commission Manuals and Guides No. 14. IOC, Paris, 83pp.

Lennon, G.W., 1971. Sea level instrumentation, its limitations and the optimisation of the performance of conventional gauges in Great Britain. *International Hydrographic Review*, 48(2), 129-147.

Noye, B.J., 1974a. Tide-well systems I: some non-linear effects of the conventional tide well. *Journal of Marine Research*, 32(2), 129-135.

Noye, B.J., 1974b. Tide-well systems II: the frequency response of a linear tide-well system. *Journal of Marine Research*, 32(2), 155-181.

Noye, B.J., 1974c. Tide-well systems III: improved interpretation of tide-well records. *Journal of Marine Research*, 32(2), 193-194.

Section 3.3.1

Pugh, D.T., 1972. The physics of pneumatic tide gauges. *International Hydrographic Review*, 49(2), 71-97.

Pugh, D.T., 1978. Techniques for the measurement of sea level around atolls. In: D.R. Stoddart and R.E. Johannes (eds.) *Coral reefs: research methods*, Monograph on Oceanographic Methodology. UNESCO, Paris, pp.93-108.

Section 3.3.4

IOC, 1994. *Manual on Sea level Measurement and Interpretation. Volume 2 - Emerging Technologies*. Intergovernmental Oceanographic Commission Manuals and Guides No. 14. IOC, Paris, 72pp.

Spencer, R., Foden, P.R., McGarry, C., Harrison, A.J., Vassie, J.M., Baker, T.F., Smithson, M.J., Harangozo, S.A. and Woodworth, P.L., 1993. The ACCLAIM program in the South Atlantic and Southern oceans. *International Hydrographic Review*, 70, 7-21.

Woodworth, P.L., Vassie, J.M., Spencer, R. and Smith, D.E., 1996. Precise datum control for pressure tide gauges. *Marine Geodesy*, 19, 1-20.

Section 3.3.5

Lennon, G.W., 1971. Sea level instrumentation, its limitations and the optimisation of the performance of conventional gauges in Great Britain. *International Hydrographic Review*, 48(2), 129-147.

Section 3.3.6

Spencer, R. and Vassie, J.M., 1997. The evolution of deep ocean pressure measurements in the U.K. *Progress in Oceanography*, 40, 423-435.

Section 3.4.1

- Gill, S.K., Mero, T.N. and Parker, B.B., 1993. NOAA Operational Experience with Acoustic Sea Level Measurement. pp. 13-25 in IOC (1994) *ibid*.
- Joseph, A., Peshwe, V.B., Vijaykumar and Desa E. 1997. Effects of water trapping and temperature gradient in a NGWLMS gauge deployed in Zuari estuary, Goa. pp. 73-82 in Proceedings of the Symposium on Ocean Electronics SYMPOL-97 (ed. P.R.S. Pillai), Cochin University of Science and Technology, India.
- Lennon, G.W., Woodland, M.J. and Suskin, A.A., 1993. Acoustic Sea Level Measurements in Australia. pp. 26-39 in IOC (1994) *ibid*.
- Shih, H.H. and Baer, L., 1991. Some errors in tide measurement caused by dynamic environment. pp. 641-671 in Tidal Hydrodynamics (ed. B. Parker), John Wiley & Sons, 883pp.
- Vassie, J.M., Woodworth, P.L., Smith, D.E. and Spencer, R., 1993. Comparison of NGWLMS, Bubbler and Float Gauges at Holyhead. pp. 40-51 of IOC (1994) *ibid*.

Section 3.4.2

- Alvarez Fanjul, E., Pérez, B., and Rodríguez, I., 2001. Nivmar: a storm surge forecasting system for Spanish Waters. *Scientia Marina*, 65, 145-154.
- IOC, 2003. Workshop on new technical developments in sea and land level observing systems. Intergovernmental Oceanographic Commission. Workshop Report No. 193. Paris, France 14-16 October 2003.
- Pérez, B. and Rodriguez, I., 1994. Redmar. Spanish Harbours tide gauge network. Processing of tidal data. *Clima Maritimo Report* 57.

Section 3.5

- IOC, 2003. Workshop on new technical developments in sea and land level observing systems. Intergovernmental Oceanographic Commission. Workshop Report No. 193. Paris, France 14-16 October 2003.
- Martín, B., Pérez, B., Alvarez-Fanjul, E., 2005. The ESEAS-RI Sea Level Test Station: Reliability and Accuracy of Different Tide Gauges. *International Hydrographic Review*, Vol.6 No. 1. 44-53.
- Woodworth, P.L. and Smith, D.E., 2003. A one-year comparison of radar and bubbler tide gauges at Liverpool. *International Hydrographic Review*, 4(3), 42-49.

Section 4

- Emery, K.O. and Aubrey, D.G., 1991. *Sea levels, Land levels and Tide Gauges*. New York: Springer Verlag, 237pp.

Section 4.4.1

- Bevis, M., Scherer, W. and Merrifield, M., 2002. Technical issues and recommendations related to the installation of continuous GPS stations at tide gauges. *Marine Geodesy*, 25, 87-99.

- Carter, W.E., (ed.) 1994. Report of the Surrey Workshop of the IAPSO Tide Gauge Benchmark Fixing Committee. Report of a meeting held 13-15 December 1993 at the Institute of Oceanographic Sciences Deacon Laboratory. NOAA Technical Report NOSOES0006, 81pp.

- Carter, W.E., Aubrey, D.G., Baker, T.F., Boucher, C., Provost, C. Le, Pugh, D.T., Peltier, W.R., Zumberge, M., Rapp, R.H., Schutz, R.E., Emery, K.O. and Enfeld, D.B., 1989. Geodetic Fixing of Tide Gauge Benchmarks. Woods Hole Oceanographic Institution Technical Report, WHOI-89-31, 44pp.

- Neilan, R., Van Scoy, P.A. and Woodworth, P.L., (eds) 1998. Proceedings of the Workshop on Methods For Monitoring Sea Level: GPS And Tide Gauge Benchmark Monitoring, GPS altimeter calibration Workshop organized by the IGS and PSMSL, Jet Propulsion Laboratory, 17-18 March 1997. 202pp.

Section 4.4.2

- Bevis, M., Scherer, W. and Merrifield, M., 2002. Technical issues and recommendations related to the installation of continuous GPS stations at tide gauges. *Marine Geodesy*, 25, 87-99.

- Ge, M., Gendt, G., Dick, G., Zhang, F. P. and Reigber, C., 2005. Impact of GPS satellite antenna offsets on scale changes in global network solutions. *Geophysical Research Letters*, 32, L06310, doi : 10.1029/2004GL022224.

- Nerem, R.S., vanDam, T.M. and Schenewerk, M.S. 1997. A GPS Network for Monitoring Absolute Sea Level in The Chesapeake Bay: BAYONET. pp. 107-115 of Neilan et al. (1998) *ibid*.

- Neilan, R., Van Scoy, P.A. and Woodworth, P.L., (eds) 1998. Proceedings of the Workshop on Methods For Monitoring Sea Level: GPS And Tide Gauge Benchmark Monitoring, GPS altimeter calibration Workshop organized by the IGS and PSMSL, Jet Propulsion Laboratory, 17-18 March 1997. 202pp.

- Teferle, F.N., Bingley, R.M., Williams, S. D. P., Baker, T. F. and Dodson A.H., 2006. Using continuous GPS and absolute gravity to separate vertical land movements and changes in sea level at tide gauges in the UK. *Philosophical Transactions of the Royal Society, London*. 364, doi: 10.1098/rsta.2006.1746.

Section 4.4.3

- Cazenave, A., Soudarin, L., Cretaux, J-F. and Le Provost, C. 1999. Sea level changes from TopexPoseidon altimetry and tide gauges, and vertical crustal motions from DORIS. *Geophysical Research Letters*, 26, 2077-2080.

Section 4.4.4

- Niebauer, T.M., Sasagawa, G.S. Faller, J.E., Hilt, R. and Klotting, F., 1995. A New Generation of Absolute Gravimeters. *Metrologia*, 32 (3), 159-180.

- Open University, 1989. *Waves, Tides and Shallow-Water Processes*. Open University Oceanography Series Vol.4. Oxford: Pergamon Press in association with the Open University, 187pp.
- Sasagawa, G., Klopping, F.J., Niebauer, T.M., Faller, J.E. and Hilt, R., 1995. Intracomparison Tests of the FG5 Absolute Gravity Meters. *Geophysical Research Letters*, 22, 461-464.
- Soudarin, L., Cretaux, J-F. and Cazenave, A., 1999. Vertical Crustal Motions from the DORIS Space Geodesy System. *Geophysical Research Letters*, 26, 1207-1210.
- Teferle, F.N., Bingley, R.M., Williams, S. D. P., Baker, T. F. and Dodson A.H., 2006. Using continuous GPS and absolute gravity to separate vertical land movements and changes in sea level at tide gauges in the UK. *Philosophical Transactions of the Royal Society, London*. 364, doi: 10.1098/rsta.2006.1746.
- Section 8.1**
- Hein, G. W., Landau, H. and Blomenhofer, H., 2000. Determination of instantaneous sea surface, wave heights, and ocean currents using satellite observations of the Global Positioning System. *Marine Geodesy*, 14, 217-224.
- Kato, T., Terada, Y., Ito, K., Hattori, R., Abe, T., Miyake, T., Koshimura, S. and Nagai, T., 2005. Tsunami due to the 5 September 2004 off the Kii peninsula earthquake, Japan, recorded by a new GPS buoy. *Earth Planets Space*, 57, 297-301.
- Schöne, T., Braun, A. and Reigber, C., 2001. Altimetrie und meeresspiegel - möglichkeiten und grenzen der Beobachtung, Zürich. *GAIA* 10, 3, 226-229.
- SSG2.194., 2003. Final Report of the SSG2.194 GPS Water Level Measurements Project. http://www.gfz-potsdam.de/pb1/op/altimetry/SSG_buoys/index.html.
- Watson, C., White, N., Coleman, R., Church, J., Morgan, P. and Govind, R., 2004. TOPEX/Poseidon and Jason-1: absolute calibration in Bass Strait, Australia. *Marine Geodesy*, 27(1-2), 107-132.
- Section 8.2**
- Anderson, K.D., 2000. Determination of water level and tides using interferometric observations of GPS signals. *Journal of Atmospheric and Oceanic Technology*, 17(8), 1118-1127, doi :10.1175/1520-0426.
- Beyerle, G., Hocke, K., Wickert, J., Schmidt, T. and Reigber, C., 2002. GPS radio occultations with CHAMP: A radioholographic analysis of GPS signal propagation in the troposphere and surface reflections. *Journal of Geophysical Research*, 107(D24), 4802, doi :10.1029/2001JD001402.
- Cardellach, E., Ruffini, G., Pino, D., Rius, A., Komjathy, A. and Garrison, J.L., 2003. Mediterranean Ballon Experiment: Ocean wind speed sensing from the stratosphere using GPS reflections. *Remote Sensing of the Environment*, 88(3), 351-362, doi :10.1016/S0034-4257(03)00176-7.
- Garrison, J.L. and Katzberg, S.J., 2000. The application of reflected GPS signals to ocean remote sensing. *Remote Sensing of the Environment*, 73, 175-187.
- Germain, O., Ruffini, G., Soulat, F., Caparrini, M., Chapron, B. and Silvestrin, P., 2004. The Eddy Experiment: GNSS-R specularometry for directional sea-roughness retrieval from low altitude aircraft. *Geophysical Research Letters*, L21307, doi : 10.1029/2004 GL020991.
- Hajji, G.A. and Zuffada, C., 2003. Theoretical description of a bistatic system for ocean altimetry using the GPS signal. *Radio Science*, 38(5), doi :10.1029/2002RS002,787.
- Hajji, G.A. et al. 2004. CHAMP and SAC-C atmospheric occultation results and intercomparisons. *Journal of Geophysical Research*, 109, D06109, doi:10.1029/2003JD003909.
- Katzberg, S.J., Walker, R.A., Roles, J.R., Lynch, T. and Black, P.G. 2001. First GPS signals reflected from the interior of a tropical storm: preliminary results from hurricane Michael. *Geophysical Research Letters*, 28(10), 1981-1984.
- Lowe, S.T., LaBrecque, J.L., Zuffada, C., Romans, L.J., Young, L.E. and Hajji, G.A., 2002. First spaceborne observation of an Earth-reflected GPS signal. *Radio Science*, 37(1), doi : 10.1029/2000RS002539.
- Martín-Neira, M., 1993. A passive reflectometry and interferometry system (PARIS): Application to ocean altimetry. *ESA Journal*, 17, 331-355.
- Martín-Neira, M., Colmenarejo, P., Ruffini, G. and Serra, C., 2002. Altimetry precision of 1 cm over a pond using the wide-lane carrier phase of GPS reflected signals. *Canadian Journal of Remote Sensing*, 28(3), 394-403.
- Pavelyev, A.G., Volkov, A.V., Zakharov, A.I., Krutikh, S.A. and Kucherjavenkov, A.I., 1996. Bistatic radar as a tool for Earth investigation using small satellites. *Acta Astronautica*, 39(9-12), 721-730.
- Rius, A., Aparicio, J.M., Cardellach, E., Martín-Neira, M. and Chapron, B., 2002. Sea surface state measurement using GPS reflected signals. *Geophysical Research Letters*, 29(23), doi :10.1029/2002GL015,524.
- Ruffini, G., Soulat, F., Caparrini, M., Germain, O. and Martín-Neira, M., 2004. The Eddy Experiment: Accurate GNSS-R ocean altimetry from low altitude aircraft. *Geophysical Research Letters*, L12306, doi :10.1029/2004GL019994.
- Treuhaft, R.N., Lowe, S.T., Zuffada, C. and Chao, Y., 2001. 2-cm GPS altimetry over Crater Lake. *Geophysical Research Letters*, 22(23), 4343-4346.

APPENDIX I.

GLOSS Requirements for Tide Gauges

(update from the third edition of the manual)

The aim of any tide gauge recording should be to operate a gauge which is accurate to better than 1 cm at all times; i.e. in all conditions of tide, waves, currents, weather etc. This requires dedicated attention to gauge maintenance and data quality control. In brief, the major requirements for GLOSS stations are (IOC, 1997):

- A sampling of sea level, averaged over a period long enough to avoid aliasing from waves, at intervals of typically 6 or 15 minutes, or even 1 minute or less if the instrument is to be used also for tsunami warning (IOC 1997 states: 'but in all circumstances the minimum sampling interval should be one hour', which these days is an insufficient sampling for most agencies);
- Gauge timing be compatible with level accuracy, which means a timing accuracy better than one minute (and in practice, to seconds or better, with electronic gauges);
- Measurements must be made relative to a fixed and permanent local tide gauge bench mark (TGBM). This should be connected to a number of auxiliary marks to guard against its movement or destruction. Connections between the TGBM and the gauge zero should be made to an accuracy of a few millimetres at regular intervals (e.g. annually);
- GLOSS gauges to be used for studies of long term trends, ocean circulation and altimeter calibration need to be equipped with GPS receivers (and monitored possible by other geodetic techniques) located as close to the gauge as possible;
- The readings of individual sea levels should be made with a target accuracy of 10 mm;
- Gauge sites should, if possible, be equipped for recording tsunami signals, implying that the site be equipped with a pressure sensor capable of 15-seconds or 1-minute sampling frequency, and possibly for recording wave conditions, implying 1-second sampling frequency;
- Gauge sites should be also equipped for automatic data transmission to data centres by means of satellite, Internet etc., in addition to recording data locally on site;
- Sea level measurements should be accompanied by observations of atmospheric pressure, and if possible winds and other environmental parameters, which are of direct relevance to the sea level data analysis.

Regular (e.g. daily) inspection of data will inform operators when a gauge is malfunctioning, and lead to overall better long-term data sets. Data from gauges in polar or other remote locations will inevitably be inspected less frequently, unless satellite data transmission can be installed. Similarly, data from the relatively few gauges recording only on paper charts will be slow to reach centres for quality control; these must be considered priorities for upgrading to meet modern standards.

Operators of gauges must always be aware of possible systematic jumps in sea level time-series when one form of recording is replaced by a 'better' one. All gauges have systematic errors, but those errors will be irrelevant for time-series work if the same technique is used throughout. New-technology gauges are, by definition, less well understood than old ones, and they must always be operated alongside the older ones until sufficient experience has been acquired.

APPENDIX II.

Previous volumes of the IOC Manual on Sea Level Measurement and Interpretation

Any reader of the present Volume of the IOC Manual would do well to also read Volumes 1, 2 and 3. They were published some years ago (in 1985, 1994 and 2000, respectively), but do contain sections that are still of interest. The contents of Volume 3 are shown below. Copies of the three earlier volumes can be downloaded from www.pol.ac.uk/psmsl/manuals

Table of Contents of Manual on Sea Level Measurement and Interpretation, v. III: Reappraisals and recommendations as of the year 2000, IOC. Manuals and guides; 14

1. Introduction

- 1.1 Historical Background
- 1.2 Tide Gauges
- 1.3 GLOSS Requirements
- 1.4 Layout of Volume 3

2. Tide Gauge Technologies

- 2.1 Acoustic Tide Gauges
 - 2.1.1 Acoustic Gauges with Sounding Tubes
 - 2.1.1.1 The NOAA NGWLMS System
 - 2.1.1.2 The Australian SEAFRAME System
 - 2.1.1.3 Other Users of Acoustic Sounding Tube Gauges and Calibration Comments
 - 2.1.1.4 Similar Hardware Available
 - 2.1.2 Acoustic Gauges in the Open Air
 - 2.1.2.1 Experience in Spain
 - 2.1.2.2 Experience in South Africa
- 2.2 Pressure Sensor Tide Gauges
 - 2.2.1 Single Transducer Systems
 - 2.2.1.1 The Datum of a Single Transducer Pressure System
 - 2.2.2 Multiple Pressure Transducer Systems ('B' Gauges)
 - 2.2.3 Pressure Transducers in Stilling Wells
 - 2.2.4 Bubbler Pressure Gauges
 - 2.2.5 Bottom Mounted Pressure Gauges
- 2.3 Float Gauges in Stilling Wells
- 2.4 Radar Tide Gauges and Other New Technologies
- 2.5 General Principles of Choice of a Tide Gauge Site
- 2.6 Comments on Desirable Recording Frequency
- 2.7 Synthesis of the Merits of Different Technologies and Recommendations

3. Data Transmission Methods

- 3.1 Introduction
- 3.2 Satellite and Global Mobile Phone Data Links
- 3.3 Packages Available within GLOSS

4. Datums and Datum Connections at Tide Gauges

- 4.1 Some Definitions (extended from Volume 1)
- 4.2 Levelling between Local Bench Marks
- 4.3 Levelling Between Wider Area Marks
- 4.4 Geodetic Fixing of Tide Gauge Benchmarks
 - 4.4.1 Introduction
 - 4.4.2 Geocentric Coordinates of Tide Gauge Benchmarks
 - 4.4.3 GPS Measurements
 - 4.4.4 DORIS Measurements
 - 4.4.5 Absolute Gravity Measurements
- 4.5 Geodetic Contact Points

5. Data Documentation and Processing

- 5.1 Documentation and Archiving
- 5.2 PC-Based Software
 - 5.2.1 Comments on Tidal Predictions
 - 5.2.2 Tidal Filters for 'Mean Sea Level'
 - 5.2.3 Comments on Computations of Extremes

6. Data Exchange Procedures

- 6.1 Background
- 6.2 Consequent Data Exchange Actions
- 6.3 Fast Delivery Data
- 6.4 Regional Programmes

7. Training Materials, Training Courses and More Information

- 7.1 Training Materials
- 7.2 Sea Level Training Courses
- 7.3 Further Information

8. References

Acknowledgement

Annex 1. GLOSS Requirements for Gauges

APPENDIX III.

List of Websites

<http://www.pol.ac.uk/psmsl/>

<http://www.pol.ac.uk/psmsl/training/analysis.html>

<http://www.stevenswater.com>

<http://www.ixsea.com> (for MORS, formerly www.oceano.co.uk)

<http://www.srduk.com>

http://www.GeneralAcoustics.com/products/index_logalevel.html

<http://www.ott-hydrometry.de>

<http://www.krohne.com>

<http://www.vegacontrols.co.uk>

<http://www.miros.no>

<http://www.seba.de>

<http://ids.cls.fr/html/report/publications.html>

<http://www.microgsolutions.com>

<http://www.pol.ac.uk/psmsl/training/levelling.doc>

http://adsc.gfz-potsdam.de/tiga/index_TIGA.html

<http://www.soest.hawaii.edu/UHSLC/>

<http://www.bodc.ac.uk>

<http://www.puertos.es>

APPENDIX IV.

List of Acronyms

ACCLAIM	Antarctic Circumpolar Currents Levels and Island Measurement	GODAE	Global Ocean Data Assimilation Experiment
ARGO	Global Array of Profiling Floats	GOES	Geostationary Operational Environmental Satellite System
ARGOS	Automatic Remote Geomagnetic Observatory System	GOOS	Global Ocean Observing System
BGAN	Broadband Global Area Network	GPS	Global Positioning System
BODC	British Oceanographic Data Centre	GRGS	Groupe de Recherches de Geodesie Spatiale (France)
CDDF	Central Data Distribution Facility	GTS	Global Telecommunications System
CGPS@TG	Continuous GPS at Tide Gauges	GTOS	Global Terrestrial Observing System
C-GOOS	Global Ocean Observing System – Coastal Module	IALA	International Association of Marine Aids to Navigation and Lighthouse Authorities
CIESM	International Commission for the Scientific Exploration of the Mediterranean Sea	IAPSO	International Association for the Physical Sciences of the Ocean
CLIVAR	Climate Variability and Predictability	ICSU	International Council for Science
CLS	Collecte Localisation Satellites	IERS	International Earth Rotation Service
CMSLT	Commission on MSL and Tides of IAPSO	IGOSS	Integrated Global Ocean Services System
CNES	Centre National d'Etudes Spatiales (France)	IGS	International GNSS Service (formerly the International GPS Service)
CP	Contact Point	IHO	International Hydrographic Organization
CPACC	Caribbean Planning for Adaptation to Climate Change	INMARSAT	International Maritime Satellite Organisation
COOP	Coastal Ocean Observations Panel	IOC	Intergovernmental Oceanographic Commission (of UNESCO)
DATARING	Data Acquisition for Tidal Applications for the Remote Interrogation of Network Gauges	IPCC	Intergovernmental Panel on Climate Change
DCP	Data Collection Platform	ISLP-Pac	IGOSS Sea Level Programme in the Pacific
DORIS	Doppler Orbitography by Radiopositioning Integrated on Satellite	JASL	Joint Archive for Sea Level (of UHSLC)
ENSO	El Niño Southern Oscillation	JCOMM	WMO-IOC Joint Technical Commission on Oceanography and Marine Meteorology
ENVISAT	Environmental Satellite	LAT	Lowest Astronomical Tide
ESEAS	European Sea Level Service	LTT	Long-Term Trends
EU	European Union	MEDALPEX	Mediterranean Sea During Alpine Experiment
EUMETSAT	European Organisation for the Exploitation of Meteorological Satellites	MEDGLOSS	Mediterranean Programme for the Global Sea-Level Observing System (of IOC and CIESM)
FAGS	Federation of Astronomical and Geophysical Services	METEOSAT	Geostationary Meteorological Satellite
FIAMS	Flinders Institute for Atmospheric and Marine Sciences	MSL	Mean Sea Level
GCN	GLOSS Core Network	MTL	Mean Tide Level
GCOS	Global Climate Observing System	NERC	Natural Environment Research Council
GE	Group of Experts (of GLOSS)	NESDIS	National Environmental Satellite and Data Information Service
GFZ	Geo Forschungs Zentrum, Potsdam, Germany	NGWLMS	Next Generation Water Level Measurement System
GIA	Glacial Isostatic Adjustment	NOAA	National Oceanic and Atmospheric Administration (USA)
GLOSS	Global Sea Level Observing System	NOS	National Ocean Service (of NOAA)
GMS	Geostationary Meteorology Satellite	NTC	National Tidal Centre of the Bureau of Meteorology (Australia)
GNSS	Global Navigation Satellite System		

OOPC	Ocean Observations Panel for Climate	SRD	Sonar Research and Development
PERSGA	Regional Organization for the Conservation of the Environment of the Red Sea & Gulf of Aden	STWS	Storm Tide Warning Service (UK)
POL	Proudman Oceanography Laboratory (UK)	TASK	Tidal Analysis Software Kit
PSMSL	Permanent Service for Mean Sea Level	TGBM	Tide Gauge Bench Mark
PSTN	Public Switched Telephone Network	TGI	Tide Gauge Inspectorate
PTT	Platform Transmitter Terminal	TIGA	Tide Gauge and GPS Benchmark Monitoring Project (of IGS)
PTWC	Pacific Tsunami Warning Centre	TOGA	Tropical Ocean Global Atmosphere
RBGAN	Regional Broadband Global Area Network	TOPEX	Joint US/French Ocean Topography Experiment
RLR	Revised Local Reference	UHSLC	University of Hawaii Sea Level Center
RONMAC	Red de Observacion del Nivel del Mar para America Central	UNEP	United Nations Environment Programme
RTU	Remote Terminal Unit	UNESCO	United Nations Educational, Scientific and Cultural Organization
SEAFRAME	Sea Level Fine Resolution Acoustic Measuring Equipment	VLBI	Very Long Baseline Interferometry
SLC	Sea Level Centre	VLM	Vertical Land Movement
SLR	Satellite Laser Ranging	WMO	World Meteorological Organization
SOC	Southampton Oceanographic Centre	WOCE	World Ocean Circulation Experiment

APPENDIX V.

Contributed Practical Experiences with Various Tide Gauge Technologies

This appendix contains contributions kindly provided by the following people:

Daniel Hareide, Hodnesdal, Tor Tørresen and Tor Ellef Hansen Østebøvik (Norwegian Hydrographic Service)

B. Martín, B. Pérez, E. Alvarez Fanjul (Puertos del Estado, Spain)

Christoph Blasi and Ulrich Barjenbruch (Federal Institute of Hydrology, Germany)

Ruth Farre (South African Navy Hydrographic Office)

Antony Joseph, Prakash Mehra, Joseph Odammetey and Nkebi E. Kofi (National Institute of Oceanography, India, and Survey of Ghana)

Juan Fierro, Chilean Navy Hydrographic and Oceanographic Service (SHOA)

Bernie Kilonsky (University of Hawaii Sea Level Center, USA)

Peter Foden (Proudman Oceanographic Laboratory, UK)

Laura Kong (International Tsunami Information Centre, Hawaii, USA)

Each of these experts is willing to discuss aspects of their experiences in more detail with anyone interested.

Float Gauges in Stilling Wells: Experience in Norway

Daniel Hareide, Hanne Hodnesdal, Tor Tørresen and Tor Ellef Hansen Østebøvik
 Norwegian Hydrographic Service, P.O. Box 60, 4001 Stavanger, NORWAY
 E-mail: daniel.hareide@statkart.no

The float gauge and stilling well

The Norwegian Tide Gauge Network, operated by the Norwegian Hydrographic Service (NHS), records sea level elevations with float gauges at 23 locations.

A typical Norwegian stilling well consists of a polyethylene tube with a conical inlet at the bottom (Figure 1). The diameter of the tube is 30 or 40 cm and the inlet (cone) is of copper to reduce marine fouling. We have seen that galvanic corrosion can be a problem, probably since we have used parts of stainless steel to clamp the cone to the tube. This can cause holes in the

cone, and unwanted wave oscillations are not reduced as they are supposed to be. Inside the cone there is a

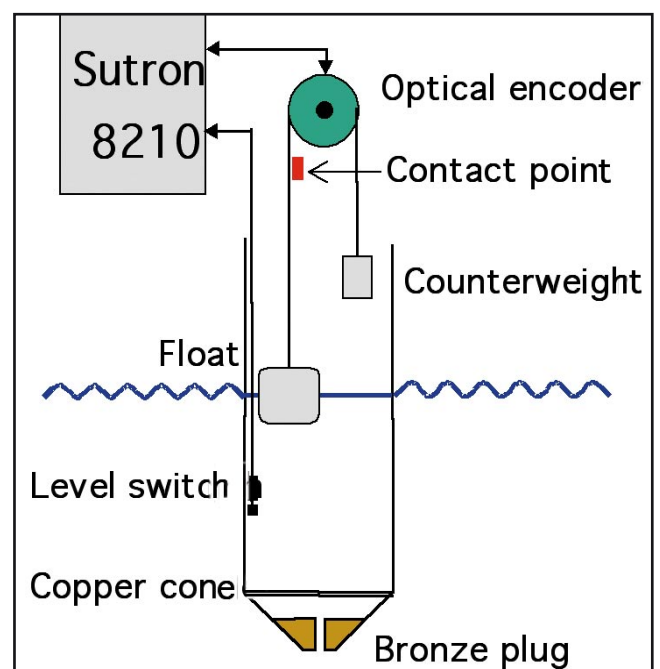
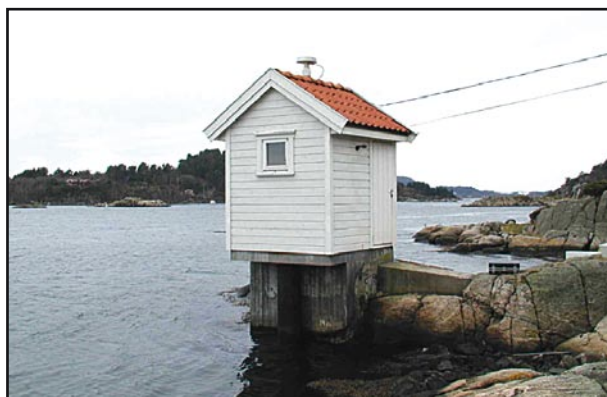

Figure 1. Sea level gauge in Norway and schematic description of stilling well with copper cone and bronze plug.

removable orifice of bronze and the orifice can be adjusted with one or more nipples. Some of the tidal stations in Norway are exposed to ice and low temperatures, and 220 V AC heating cables are installed inside these wells.

Each sea level gauge has at least one level switch used for quality control. It is installed inside the stilling well approximately at mean sea level (MSL). The level switch is a tiny float, which switches a current loop when the sea level passes the level at which the switch is mounted. The computer registers the time and sea level when the switch turns on or off, and these data can be compared with the level at which the switch is mounted. The level switch has been very important in the detection of several problems, such as drift (trend) in the observations.

An encoder with an SDI-12 output is installed above the tube, mounted on a concrete block (Figure 2). The encoder has a sprocket (wheel) on the shaft and is programmed to give an output with a resolution of 0.1 cm. The encoder has internal battery backup which remembers the angular position, in case of power failure. A chain with a float and a counterweight runs over the sprocket and the sea level is given by the angular position of the sprocket. It is important that the sprocket and chain fit well together. If not, there could be very small tangential movements between the sprocket and chain and this in turn presents itself as very slow drift (trend) in the sea level observations. NHS is using a US manufacturer of the chain and sprocket (W.M.Berg Inc. (www.wmberg.com)). Leading marks on the chain and sprocket make it easy to control the system.

The data logger is a Sutron 8210 and it collects and stores sea level, barometric pressure and switch-level data. The memory of the Sutron 8210 has battery backup and can hold several months of data. Normally the data are retrieved twice a day from the data logger, sometimes more often. The data logger has a serial port, which is used for communication, either through the ISDN-network or with a GPRS-router. We are now in the process of converting the data transmission from the ISDN-network to GPRS-router for all the tidal stations. This work will be completed during the next 2–3 years (depending on allocated budget) and sea level data will be sent to the office in Stavanger every 10–20 min and will be immediately (an automatic quality control is applied to the data) available on our website.

The data logger and the communication unit have separate battery backups. The data logger has less power consumption than the communication unit, so, in case of power failure, the gauge will continue to store data even if the communication is broken.

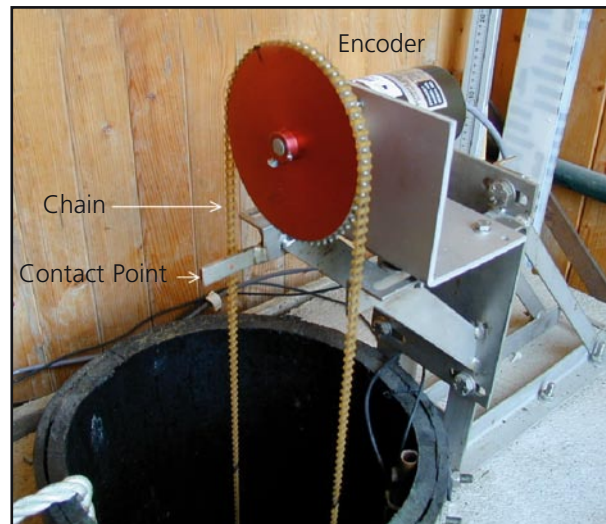

Figure 2. Encoder, chain and contact point.

Levelling is done from the TGBM and one or two additional benchmarks to a contact point at the same bracket as the encoder. The TGBM is in solid rock as close to the sea level gauge as possible. After modernization of the gauges between 1985 and 1991, levelling has been done every year. Since most of the gauges are located on stable ground, the levelling interval now is three years, except for a few gauges which are sinking. The levelling follows the procedures outlined in the UNESCO Manual on Sea-Level Measurement and Interpretation, Volume I, and the accuracy is millimetric. It is more difficult to calibrate the sea level gauge to the same accuracy. Calibration is done by measuring the distance from the sea surface to the contact point with a levelling staff inside the well, and by taking simultaneously readings on the sea level gauge. This is repeated several times, and the sea level gauge is calibrated by making its readings equal to the observations on the staff. Taking many readings will reduce the problem with a moving sea surface. There might, however, be some individual differences in the way the calibration is performed and this may introduce systematic errors of a few millimetres. We use a sea level gauge zero that is below the lowest observed sea level. To avoid any confusion, we never use levels like Chart Datum or Land Survey Datum as the gauge zero.

The sea level gauges are inspected at intervals of 18 months. We should like to carry out levelling and inspections more frequently, but we have to reduce the operational costs as much as possible.

For all stations, a close co-operation with local operators is essential. They look after the equipment and assist us in various situations, i.e. when there are power or communication problems with the gauge.

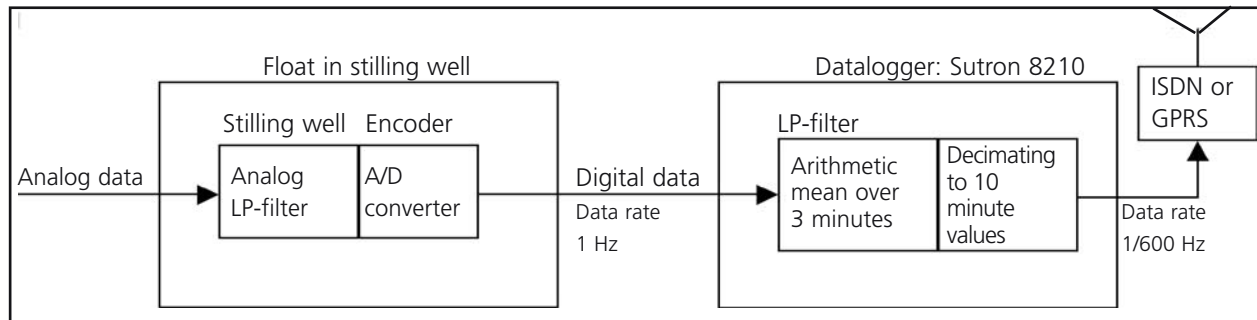

Figure 3. Schematic description of sampling and filtering in sea level gauge.

Sampling and filtering in the sea level gauge

The stilling well represents a mechanical low pass (LP) filter. The attenuation R depends on the relationship between the area of the cross-section of the well and the area of the orifice: $R = (\text{area of well})/(\text{area of orifice})$ (Forrester 1983). This relationship also affects the response time, which is defined as the time it takes before the sea level on the inside has changed to the mid-point of a sudden and permanent change on the outside. A high value of R gives high attenuation and long response time. It is recommended by Forrester (1983) to choose $R = 100$, which will pass waves with periods of, for example, 12 h (representative for tide) and periods of 6 min (representative for harbour seiche), but will attenuate waves with a period of 6 s (representative for surface swell). The -3 dB cutoff frequency will be roughly $1/40$ Hz (taken from plot in Shih and Rodgers (1981). $R = 100$ signifies a response time of 11 s (Forrester 1983). Most of our sea level gauges have R close to 100. A sampling frequency of 1 Hz inside a stilling well of this type should be satisfactory.

In the datalogger a 3-min arithmetic mean is calculated every 10 min. Studies at NHS have shown that this filter does not remove all frequencies above the Nyquist frequency for 10-minute sampling ($f_{Ny} = f_s/2 = 1/(2 \times 10 \times 60)$ Hz = 0.0008333... Hz). There is now a test of calculating the 1-minute arithmetic mean every minute in the data logger and transmitting 1-minute data to the office. In this case the filter is better suited for the sampling rate, and we shall get access to a higher data rate as well.

Processing of data at the office The received data are stored in a database. Automatic and manual quality control are applied to the data.

One-hour values are used for the harmonic analysis. To avoid aliasing, all frequencies above the Nyquist frequency (f_{Nyq}) should be removed before decimating from 10-minute values to 1-hour-values. The Nyquist frequency f_{Nyq} is half of the sampling frequency $f_s = 1/(1 \text{ hour})$.

A 4th-order Butterworth filter is used for this purpose (Hodnesdal 1983; see amplitude response in Figure 4). The cut off frequency is $1/3$ hours). The time-series is run forwards and backwards through this filter to ensure zero phase response. The squared amplitude response is

-29.4 dB ($=0.034$ Hz) at f_{Nyq} . This is an acceptable anti-

$$f_{Nyq} = \frac{f_s}{2} = \frac{1}{1 \text{ hour} \cdot 2} = \frac{1}{60 \cdot 60 \cdot 2} \text{ Hz} = 0.0001388... \text{ Hz}$$

aliasing filter because almost all energy above the Nyquist frequency is removed. The problem is, however, that some of the over-harmonic constituents will be partly filtered as well. Frequencies from the fifth-diurnal (period of circa 4.8 h) and higher will be attenuated by the filter. For stations with significant shallow water constituents, a filter with a higher cut-off and faster roll-off should be used.

For further information, go to: <http://vannstand.statkart.no/>

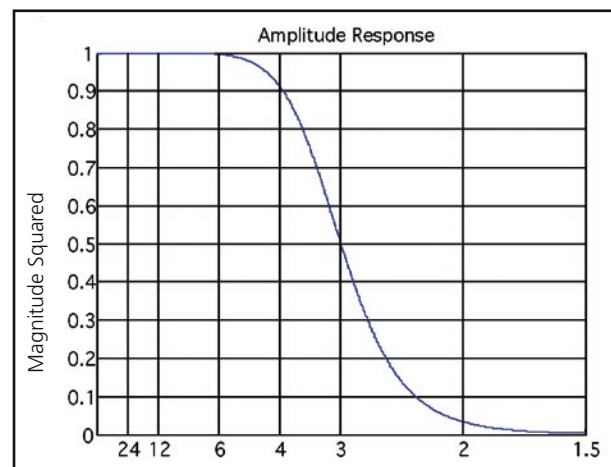

Figure 4. Amplitude response of 4th-order Butterworth filter.

References

- Forrester, W.D. 1983. Canadian Tidal Manual. Department of Fisheries and Oceans, Canadian Hydrographic Service, Ottawa. 138pp.
- Hodnesdal, H. 2003. Use of Butterworth filter for LP-filtering of water level data in NHS. Technical Report. Norwegian Hydrographic Service, Stavanger, Norway.
- Shih, H.H. and Rogers, D. 1981. Error analysis for tide measurement systems utilizing stilling wells. Technical Report. US Department Commerce, National Oceanic and Atmospheric Administration (NOAA), USA.

The ESEAS-RI Sea Level Pilot Station in Vilagarcía de Arousa (Spain)

B. Martín, B. Pérez, E. Alvarez Fanjul
Puertos del Estado, Madrid, Spain, E-mail: bego@puertos.es

Introduction

During the ESEAS-RI project (European Sea Level Service – Research Infrastructure), a test station for sea level sensors was established at Vilagarcía de Arousa, on the northwest coast of Spain. One of the objectives was to experiment with different kinds of radar sensor, an emerging technology for measuring sea level, and compare their performance with other traditional and well proven tide gauges. The main advantage of radar appeared to be its demanded accuracy, low maintenance and lack of influence of air temperature, humidity or density of the water. The experiment was carried out when the existing networks were requiring renewal, owing to the age of the equipment, and radar appeared as an even better option than acoustic sensors, and possible new applications of sea level data had to be taken into account.

Experiment and description of the sensors

The period of operation of the different tide gauges is shown in Figure 2, and varies mainly due to the different dates of incorporation into the experiment and to problems encountered during the first year, sometimes even due to lack of experience with the equipment. Most of the equipment installed is very well known and described in the literature and in previous IOC manuals, such as the pressure (both the single pressure sensor and the bubbler sensor from POL) and the acoustic gauges (both the Aquatrak from NOAA and the SRD from the REDMAR network). As was mentioned, the main contribution of the experiment was the testing of several new radar sensors and the simultaneous installation of so many tide gauges for the first time.

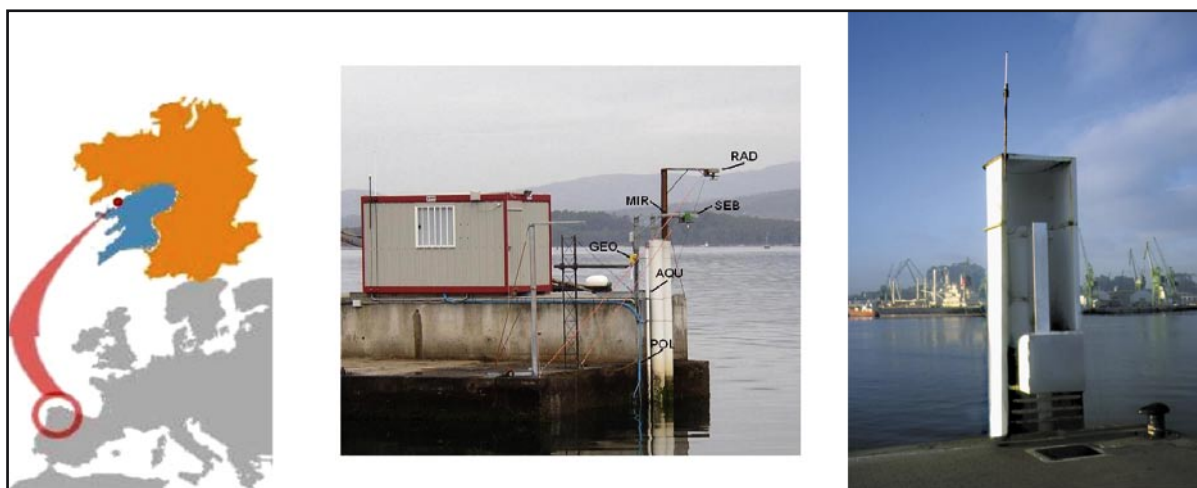

Figure 1. Location of Vilagarcía de Arousa (left), photo of the test station (centre) and of the REDMAR station (right, an SRD acoustic sensor on another dock).

The main modern technologies have been tested in Vilagarcía: pressure, acoustic and radar, a total of eight different sensors. Different institutions and private companies provided sensors for the test; the National Oceanographic and Atmospheric Administration (NOAA, USA) lent an Aquatrak acoustic sensor, and the Proudman Oceanographic Laboratory (POL, UK) lent a bubbler pressure sensor. Apart from this, two FMCW radar sensors were provided by the companies Miros and ENRAF (Radac). The contribution of Puertos del Estado was the acoustic sensor of the REDMAR network (SRD), and two pulse radar stations: Seba and Geónica. Finally, a SeaBird pressure sensor was also installed during the experiment by the maintenance company SIDMAR Bernhard Pack.

Focusing on the radar technology, two different types of radar were installed (sensors were always located at a certain height above the sea surface):

Pulse radar: operates on a similar principle to that of the acoustic sensor, by measuring the travel time of microwave pulses between the sensor and the water surface and the return echo to the sensor. The main advantage over the acoustic gauges is that the velocity of propagation (light velocity, c , in air) of the wave does not depend on environmental conditions, in particular on temperature gradients along the path of the pulse. This makes the installation requirements less strict and no protective tube or pre-measurement calibration is needed. Geónica and Seba radars are pulse radars and in fact use the same Vegapuls transducer.

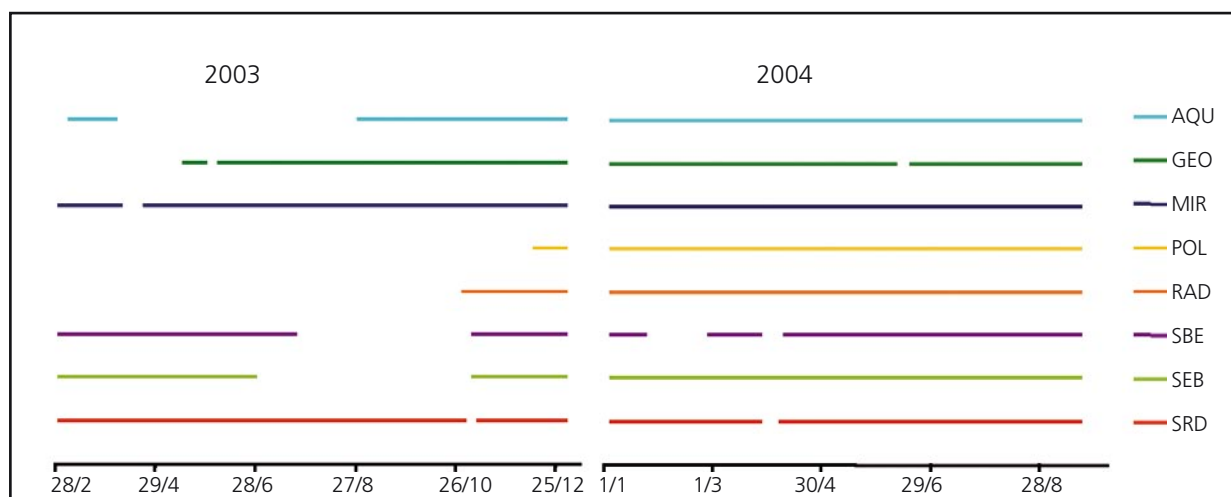

Figure 2. Period of operation of the different sensors during the two years of the experiment (the SeaBird [SBE] data are not included in this report).

Frequency-modulated continuous-wave (FMCW):

this is a more accurate method of measuring distance with radar, by modulating the frequency of a continuously emitted wave. A phase shift between the emitted wave and the reflected wave occurs, and the mix results in a low-frequency signal (beat frequency) which provides a measurement of the distance. Mirros and Radac sensors are FMCW radars.

In any case, the installation of these instruments is much easier and less expensive than the one required by the acoustic or the bubbler sensors. On the other hand, radar sensors have the advantage of being located above the sea surface, so maintenance is easier than for pressure sensors.

Some of the systems allowed the storage of data every second (Aquatrak, Mirros and Radac), whereas others stored averaged values: 10-s (POL bubbler), 1-min (Seba and Geonica) or 5-min (SRD). Only the Geónica tide gauge had a GPS-controlled assignment of time. The station was routinely maintained by the company SIDMAR every four months, as is usually also done for the permanent REDMAR station, and this was the frequency of adjustment of clocks for the rest of the installations. Apart from this, levelling of the transducer, datum calibration and downloading of data, as well as draining of the bubbler compressor and the checking of the oil level and air pressure, were all activities performed during a maintenance campaign.

During the experiment, the installations that operated better and yielded a larger amount of data were the Geónica, Mirros and POL bubbler sensors, as well as the permanent SRD station. The percentage of spikes in the data sets was very small, particularly for all the radar sensors which also withstood the storm season without failing.

Five-minute data comparison

Comparison of raw data is a difficult task, since, depending on the time interval, installation characteristics (within a tube or in the open air) and measuring technique, each sensor really measures different things. So the first step was to obtain 'comparable' time-series, and averages over 5-min intervals were computed (also the time interval for the raw data of the SRD tide gauge).

During the experiment, differences of up to 6 min were found, with an impact on the mean difference between two sensors of up to 5 cm. To correct for this effect, normally not attributable to the sensor but to the PC where data were stored, a correction of time shifts for multiples of 1 min was made for 3-day data windows. Although not possible during the Vilagarcía experiment, a precise control of time assignment, by GPS or Internet (in case of a PC) should be no problem for any tide gauge nowadays. That is why we thought it would not be reasonable to consider problems of time as a shortcoming of the sensor itself.

Table 1. RMS (root mean-square error), in centimetres, of the differences between each pair of sensors (data every five -minutes).

	AQU	GEO	MIR	POL	RAD	SEB	SRD
AQU	0.0	1.4	1.9	1.4	1.7	1.6	1.5
GEO	1.4	0.0	1.2	1.0	0.9	0.7	1.3
MIR	1.9	1.2	0.0	1.6	1.1	1.3	1.8
POL	1.4	1.0	1.6	0.0	1.4	1.2	1.4
RAD	1.7	0.9	1.1	1.4	0.0	1.0	1.6
SEB	1.6	0.7	1.3	1.2	1.0	0.0	1.4
SRD	1.5	1.3	1.8	1.4	1.6	1.4	0.0

For this timing correction, the reference was of course the Geónica sea level series, as it was the only one with GPS assignment of time during the experiment. Table 1 shows the RMS errors of comparisons for each pair of sensors after adjustment for time. These range from 0.7 cm (corresponding to Geónica and Seba, which is reasonable, since they use the same type of radar sensor) and 1.9 cm (Aquatrak and Miros, mainly due to an effect of temperature on the Aquatrak being higher than expected and not corrected). These values decreased by about 10% when repeated with the filtered hourly values. Following Woodworth and Smith (2003), who state that RMS values below 1.4 cm for the differences yield a precision better than 1 cm for each sensor, most of the tide gauges would meet this condition (GLOSS standard) for 5-min data, and all of them would do so for hourly data.

By computing the slope of the linear regression for each pair of sensors, an idea of the sensitivity of the sensor to the tidal range was obtained. The most interesting conclusion in this context is that the bubbler gauge from POL was the one that recorded lower ranges (around 0.5%). The explanation for this is that it has operated assuming a constant salinity, which may not be realistic for Vilagarcía harbour, which is located in an estuary (ría). More details of this comparison can be found in the technical report of the experiment or the publication included in the reference (Martín et al., 2005).

Spectral analysis

To get an idea of the differences among the time-series for each frequency band, a spectral analysis was made for one month of data from all the sensors, as well as from the 5-min time-series. Figure 3 illustrates these differences, showing that all the sensors have exactly the same response to tidal frequencies, with differences only beginning to show up for frequencies corresponding to 30 and 100 min, for which it is very clear that the Miros sensor presents more energy. This might be important for the study of oscillations of these periods, such as seiches; so we thought the company should investigate it, which they did and found that it was due to a problem, now solved, in an internal interpolation algorithm of the sensor.

Of course, the larger differences are found for frequencies larger than 0.05 cycles/minute, and this was not a surprise for us, being due to the different measuring technique and the fact that some of the sensors (acoustic) measure inside a tube and others not (radar). On the other hand, for the computation of the 5-min data, different amounts of raw data were used, depending on the sensor. Of course, differences in this range of frequency may still be significant if one needs to detect seiches or tsunamis, since we are talking about periods of between 10 and 20 min. That is why a more detailed study of the response of the different sensors at higher frequencies is required.

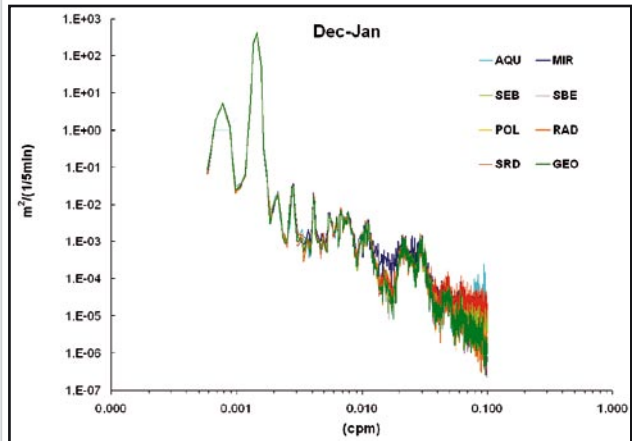

Figure 3. Power spectral density for the 5-min time-series (December 2003–January 2004).

Comparison of hourly values and daily means

To complete the study concerning standard sea level applications, a harmonic analysis for all the sensors was carried out, following the standard procedure employed by the Puertos del Estado (filtering to hourly values, and use of Foreman tidal programme). Table 2 shows the results for the main harmonics, which are very similar (differences similar to the analytical error). Again, the POL sensor shows the lowest M2 amplitude, consistent with what was said above.

The daily means were computed and compared, and trends during the period of the experiment were found to be consistent for all sensors, in spite of the limitations in the operation of the sensors and in the calibration of the datum, an aspect which was not fully considered at this test site.

Table 2. Main tidal constituents for each of the sensors, for the period December 2003–June 2004.

H (cm)							
Tide	AQU	GEO	MIR	POL	RAD	SEB	SRD
O1	6.3	6.4	6.3	6.3	6.4	6.3	6.3
K1	6.6	7.3	7.3	7.2	7.4	7.3	7.4
N2	23.4	23.3	23.4	23.2	23.5	23.6	23.7
M2	114.3	114.2	114.4	113.8	114.2	114.2	114.6
S2	40.9	40.9	41.1	40.8	41.0	41.0	40.7
G (deg)							
Tide	AQU	GEO	MIR	POL	RAD	SEB	SRD
O1	71.8	73.5	71.1	70.5	71.3	71.0	71.7
K1	48.0	53.1	54.0	51.8	51.3	52.7	60.0
N2	66.9	68.1	66.9	67.0	67.9	66.9	64.5
M2	80.0	80.5	79.9	80.0	80.5	79.9	79.3
S2	104.9	105.1	105.2	105.3	105.8	105.2	104.9

Conclusions

All the sea level sensors installed at Vilagarcía have been shown to be accurate enough for such standard applications as tide, storm surges, and even mean sea level, although the latter would need more study, to be completely sure. However, differences were found in the higher frequency range, which we have decided to continue to study. The reason for this is our interest, and may be that of the rest of the sea level community, to detect seiches and tsunamis and even include the sensors in an alert system. Concerning this, the sensors with a lower sampling frequency of the raw data should demonstrate that they are not measuring just noise, but also other physical signals.

Concerning the radar sensors, a very important conclusion is that they have shown that they are very easy to install and require almost no maintenance, which is very important for equipment for permanent networks. Nearly no incident occurred during the two years of testing, especially with the Miros and Geónica sensors; only the Seba sensor was an exception. Nevertheless, care has to be taken when stating something like this, because, sometimes, a lack of information on the sensor configuration and installation requirements may be just the explanation for some of the failures.

More detailed description of the experiment and discussion of the data can be found in ESEAS-RI (2005) and Martín et al. (2005).

References

- ESEAS-RI. (2005) Assessment of accuracy and operational properties of different tide gauge sensors. WP4 Deliverable D4.1, Technical Report. (<http://www.e seas.org>)
- Martín, B., Pérez, B., Alvarez Fanjul, E. 2005. The ESEAS-RI sea level test station: reliability and accuracy of different tide gauges. *International Hydrographic Review*, 6, 44-53.
- Pérez, B. and López Maldonado, J.D. 2003. Experience with Sonar Research and Development (SRD) acoustic gauges in Spain. IOC Workshop Report 193
- Woodworth P.L. and Smith D.E. 2003. A one-year comparison of radar and bubbler tide gauges at Liverpool. *International Hydrographic Review*, 4, 2-9.

Comparison of Radar Devices in Germany

Christoph J Blasi and Ulrich Barjenbruch
Federal Institute of Hydrology (BfG), D-56002 Koblenz, Germany,
E-mail: blasi@bafg.de

Nearly all kinds of engineering in coastal area rely on the available information on water level. The classical way of reading the water level is by a staff gauge and a float. These measuring systems were used for a very long time and were upgraded in various ways to store the recorded data.

In the late 1990s, radar devices, which were mainly used in process technology, were introduced into hydrometry. The Federal Institute of Hydrology (BfG) made the first investigation at the beginning of 2000 (BfG 2002). As technology of these devices developed, additional tests were made. These tests were part of a research project with the aim of finding the core foundation for measurements of waves, sea state, water level and thickness of ice. The results are quite reasonable and available via <http://www.bafg.de/servlet/is/7833/>. One of the main parts of the project was the measurement of waves in a broader sense. Therefore a lot of attention was paid to the theory of detection and measurement of water level as a part of waves under different conditions. Different tests were undertaken under both laboratory and field conditions to access the influence of the measurement.

The aim of this paper is to show the results from the field test, with a view to giving the reader help and support in choosing the right radar gauge to measure water level. However, the physical background and the application of radar in distance measurement will not

be discussed here. The reader may refer to the report of the research project available from the authors [please cite the source]. As mentioned before, there were tests in the hydraulic laboratory and as well in the field. During the laboratory test, the backscatter from different radar devices for various wave types and water surfaces were investigated to determine the suitability for wave and water-level measurement.

With this information, four different devices were chosen for the field test. The field test was at the gauging station on Borkum Südstrand, which is on the island of Borkum and very close to the border with The Netherlands. This location has all the required conditions, such as tidal range, different types of wave, sea state, changes of salinity, rough seas, saline air and annual temperature variation. Furthermore, the Borkum Südstrand Gauging Station is an official gauge of the Water and Shipping Way Authority. The gauge and the setting up of the radar sensors are shown in Figure 1.

The devices themselves are described as Rad_A up to Rad_D. This was done under an agreement with the manufacturers. If detailed information is required, the reader may contact the author. For establishing the reference for the four radar sensors and the official gauge, a calibrated Magnetostrictive-Sensor (a special kind of float gauge without a stilling well) was used. Most of the radar gauges work on the same principle.

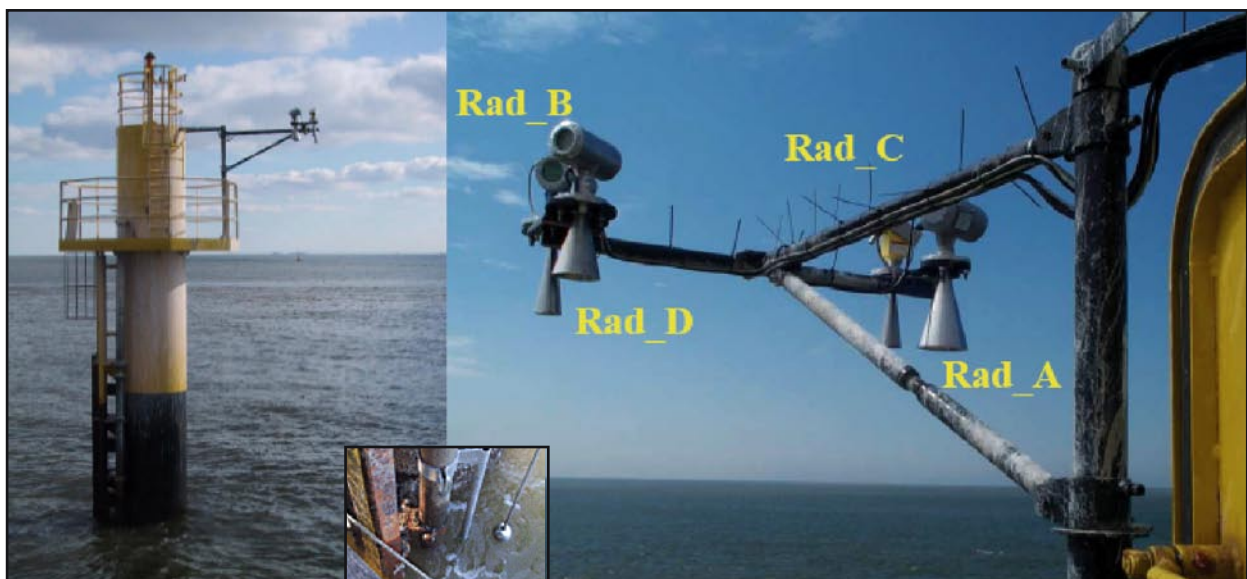

Figure 1. The Borkum Südstrand Gauging Station and installation of the of the radar gauges and the local reference.

A radar signal with a frequency of approximately 1–30 GHz is sent from the antenna to the water surface. After reflection at the water surface, the return signal is received, with a time lag. The characteristic of the radar gauge is written in Table 1.

Table 1. Characteristics of the tested radar gauge.

		Rad_C	Rad_B	Rad_D	Rad_A
Method	[-]	Pulse	Pulse	Pulse	FMCW
Microwave frequency	[GHz]	26	26	5.8	8.5-9.9

The Rad_A gauge works with the frequency modulated continuous wave (FMCW); all the other devices work with the pulse method, at different frequencies. As all radar gauges have outliers in the data, the recorded time-series has to be examined in this way and the data have to be smoothed. The exponential smoothing, with a weighting factor of 0.001 at a sample rate of 1.3 Hz achieved the best results. Figure 2 shows the measured error probabilities of the radar gauges and the official gauge.

In conclusion, the radar gauges Rad_C and Rad_B are the most suitable devices for measuring water level. The error is in the same range as that of the official gauging station. The Rad_A sensor is the only one with another measuring procedure. The pulse method (see Table 1) for the water level measurement is more suitable. Rad_D, which has also been tested since summer 2003, had problems with its data communication system. Therefore the analysis shown in Figure 2 was not done. Furthermore, compared to the classical gauge, the maintenance for the radar gauge is much less and the latter has delivered data since summer 2003. Even various environmental factors, such as bird excrement or saline air, have no influence at all on the measurement.

References

Barjenbruch, U., Mai, S., Ohle, N., Mertinatis, P. 2002. Monitoring water level, waves and ice with radar gauges. Proceedings of the Hydro 2002 Conference, Kiel, Germany. pp.328-337
 BfG (Bundesanstalt für Gewässerkunde). 2002. Test von Radarsensoren im Küsten- und Küstenbereich, interner Bericht. BfG-1276, Koblenz, Germany

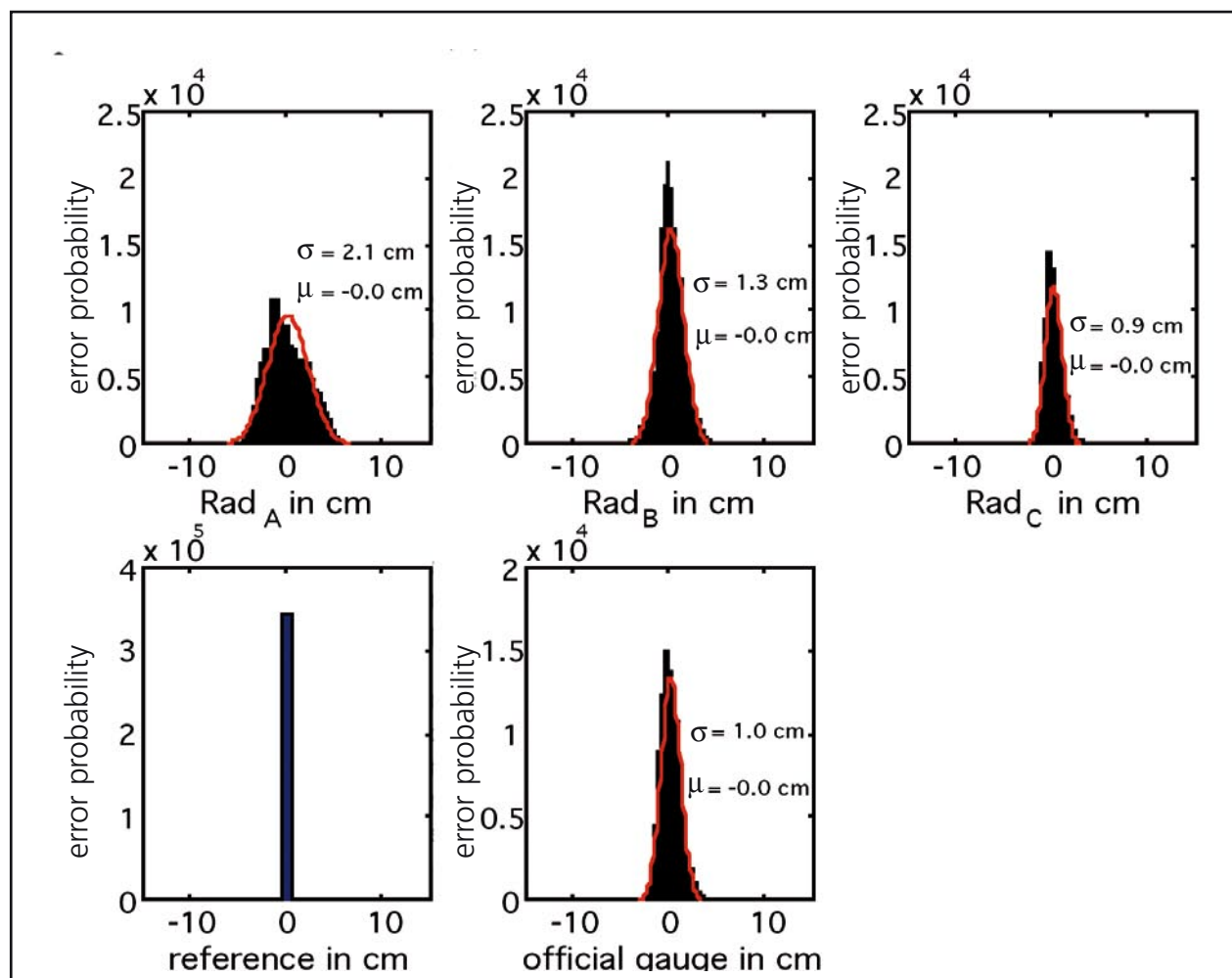

Figure 2. Comparison of the measured differences between each gauge and the Magnetostrictive-Sensor for a particular day.

Experience with SRD Tide Gauges and the Reasoning behind a Change to Radar Tide Gauges

Ruth Farre

South African Navy Hydrographic Office, E-mail: hydrosan@iafrica.com

Historical summary

The SAN Hydrographic Office started installing its own float-actuated 'Kent' gauges in 1958. As these gauges aged, additional types, also float-actuated, were installed; they comprised LEA gauges, similar to the Kents, Italian SAIP gauges in Saldanha and Simon's Town, and OTT gauges in Port Elizabeth and Walvis Bay. These gauges proved to be reliable, but by the mid-1980s, the Navy's Tide Gauge (TG) network was ageing. Spares for the Kents were becoming difficult to come by and replacement on a significant scale was urgently needed.

A project was initiated with the CSIR, Stellenbosch, to develop an accurate, modern Acoustic Water Level Recorder. These came into service in 1990 and eight were installed throughout RSA and Namibia. These gauges were a failure. They were erratic, difficult to tune and grossly inaccurate. Virtually no usable data were obtained and the gauges were finally abandoned between 1996 and 1998.

Specifications for the replacement gauges were drawn up in conjunction with IMT (Institute of Maritime Technology) in 1995 and were tendered for in 1996. The tender was won by Messrs SMD Electronics CC, with their SRD acoustic gauges meeting our requirements. These promised well and were installed, somewhat hurriedly, in 1996, mounted on tubes, as recommended by the manufacturers. The supplier stated that the gauges were calibrated in the factory and were therefore self-calibrating. It was immediately found that the gauges were very inaccurate, well outside the specification. With assistance from IMT, remedial measures were taken and the gauges were calibrated by IMT and remounted without tubes. The Hydrographic Office had to devise a method for check-calibrating these gauges *in situ*. Their performance has subsequently been just acceptable, but not of the accuracy desired. Their reliability has varied. Maintaining correct readings and downloading the data are problematical.

An OTT Kalesto Radar tide gauge was tested by the Hydrographic Office in Simon's Town at the beginning of 2002. The results obtained from this test were reaffirmed by a test done at IMT in September 2002. The results from these tests indicated that the Kalesto gauge performs with a higher degree of accuracy and stability than has been encountered in the past.

Currently the SA Hydrographic Office maintains 10 tide gauges along the South African coastline. The network is as follows:

- Port Nolloth – A Kalesto gauge is installed. A HARTRAO GPS Rx is also fitted.
- Saldanha Bay – At present there is an SRD gauge installed.
- Cape Town – At present there is an SRD gauge installed.
- Simon's Town – At present there is an SRD and a Kalesto gauge installed. A HARTRAO GPS Rx is also fitted.
- Mossel Bay – At present there is an SRD gauge installed.
- Knysna – At present there is an SRD gauge installed.
- Port Elizabeth – A Kalesto gauge is installed
- East London – A "Kalesto gauge is installed.
- Durban – At present there is an SRD gauge installed.
- Richard's Bay – A Kalesto gauge is installed. A HARTRAO GPS Rx is also fitted.

The Hydrographic Office has purchased new Kalesto radar gauges with the intention of installing them until such time as the entire South African tide gauge network has been upgraded.

SRD gauges

An independent study was done on the SRD gauge, by IMT, after the SAN Tidal Superintendent expressed concern over the accuracy and quality of the data being generated by the SRD tide gauge network. The study showed that transducers housed in tubes produced large errors due to temperature gradients that formed in the tube. The solution to this was to remove or modify the existing tubes to maintain a thermally well mixed air column around the transducer

The accuracy of the two gauges used in the study was tested: one was found to have a systematic error of about 6 mm per metre over and above a fixed offset of about 24 mm. The other was found to have a systematic error of approximately 10 mm per metre with a fixed offset of about 36 mm. This accuracy problem was taken up with the manufacturers to establish why the claimed accuracy of 0.05% over the 2- to 10-m working range could not be achieved with the units

under test. The manufacturer could not solve the problem and a method of post-data-processing was devised to improve the absolute accuracy of the data back to the claimed 0.05%. This post-data-processing could however only be carried out once all gauges in the network had been calibrated *in situ* to establish their individual calibration factors.

A refined method for *in situ* calibration was devised as a quality control tool. The method allows the following to be reliably established on site:

- Absolute accuracy
- Measurement repeatability
- Instrument datum offset.

All gauges in the SAN tide gauge network are now calibrated every six months, using carbon graphite poles of known length and a stainless steel target that is suspended below the gauge.

Data received from the gauge are very 'spiked'. The stability of the readings is also erratic. This spiking in the data creates a problem when the time arrives for the annual tidal prediction run. The spikes have to be edited out of the data by hand – each day's data have to be manually plotted, checked against the graphics produced by the Tech Tidal Assistant and then edited into the analysis programme, before predictions can be calculated. This is a very unscientific, time-consuming process and human error comes into play.

The quality of the lightning protection within the unit is not up to standard. A perfect example of this is the gauge in East London. It was struck by lightning and this caused a fire in the gauge. Since the Hydrographic Office had placed the instrument box inside a water-tight metal box, the fire burnt itself out, owing to lack of oxygen. It would appear that the data logger was not damaged in the lightning strike/fire. The power supply, junction-box telephone line and modem were damaged.

What the tidal department calls a 'kick-start' is the solution to the problem of periodic unwillingness to download data. Periodically, the power supply has to be disconnected from the gauge, followed by a wait of 30 seconds and then restoration of the power supply. This problem is becoming more and more frequent and the down-time that it is creating in data analysis is becoming problematical.

In the last five years it has become evident that the transducers are beginning to rust and this is getting progressively worse. The HO is unsure whether the rust is affecting the quality of the data; however, this is a possibility, as the transducers that have little or no rust are not creating as many problems.

Kalesto radar gauge

The OTT Kalesto radar gauge was tested by the Tidal Department and under calibration from 12 to 15 April 2002. After analysis of 1,443 readings (with a mean of 2.4955 m, say 2.496 m) it was found that, in general:

- 81% of the readings were within 2 mm of the above-stated mean
- 93% of the readings were within 3 mm of this mean
- 97% of the readings were within 5 mm of this mean.

An independent study to check-calibrate the Kalesto radar tide gauge was carried out by IMT on request by the SAN Tidal Superintendent. The study showed that, during the calibration period, the Kalesto performed consistently within the manufacturer's claimed accuracy parameters over the 2–7 m range. The absolute accuracy of the gauge under test had a standard deviation of better than 3 mm over the 2–7 m range. The independent study confirmed the results achieved by the SAN Hydrographic Office.

The refined method for *in situ* calibration devised for the SRD tide gauge as a quality control tool is used to calibrate the Kalesto gauge every six months.

The data received from the gauge have very little 'spiking' in the graphics; this is due to the 17 s measuring interval. The low spike density is evident in the graphics and in the long run there will be very little editing of the data before the predictions can be produced, thus improving on the accuracy of the Hydrographic Office's predictions. The quality of data being sent to the GLOSS Fast Centre has also increased, not only in quality but also in frequency of data transfer. (Fast Data)

This gauge is factory-fitted with an integrated lightning protector to reduce the possibility of damage caused by excess voltage (e.g. lightning or power surges.)

Future prospects

The SAN Hydrographic Office intends to upgrade its entire tide gauge network with the Kalesto radar tide gauges. It is proposed to install a GPS receiver at Durban. It is also proposed to install a tide gauge and GPS receiver on Marion Island, in connection with HARTRAO, thus restoring the South African GLOSS station status to its original 100% capability.

Currently, 'fast data' are being sent to the GLOSS Fast Centre, at the University of Hawaii, from the Simon's Town, Richards Bay, Port Nolloth, Port Elizabeth and East London gauges. The remaining RSA stations will be included in the fast-data streams once they have been upgraded to the Kalesto radar gauge.

Pressure-gauge-based GLOSS Sea Level Station at Takoradi Harbour (Ghana, West Africa): Experience over a Year

Antony Joseph (+), Prakash Mehra (+), Joseph Odametey (#), and Nkebi E. Kofi(#),

(+) National Institute of Oceanography of India (NIO); (#) Survey of Ghana (SOG) E-mail: joseph@darya.nio.org

Introduction

A GLOSS sea level station was commissioned at Takkoradi harbour in Ghana on 1 July 2004 and a year's data have been collected so far. The gauge has been developed at NIO and was installed with logistic support from the SOG.

Pressure gauge

Sea level is detected by a temperature-compensated piezoresistive semiconductor pressure transducer (PPTR) located ~1.70 m below the Chart Datum (CD) level. In conformity with the GLOSS requirements, the gauge logs 15-minute-averaged time-indexed pressure data at 15-min intervals.

Bottom pressure versus sea level

Translation of bottom pressure measurements to sea level elevations is achieved conventionally with the use of seasonally measured water density measurements. However, Joseph et al. (1999, 2004) have reported inaccuracies creeping into bottom-pressure-based sea level measurements in shallow coastal water bodies; such inaccuracies arise primarily from various poorly understood site-specific influences, which results in the effective density (ρ_{eff}) of the water being generally lower than that obtained from conventional measurements using CTD or a density meter. In view of this, an alternate method for translation of bottom pressure measurements to sea level elevations without the use of water density measurements has been explored. This method involves the use of a statistically derived mathematical model, which relates a sufficiently large set of bottom pressure measurements and concurrent good-quality tide-staff measurements for a given installation. The model representing the linear regression between these two measurements is of the form $T = [(G \times P_w) - O]$ where T , P_w , G and O represent, respectively, chart-datum-referenced tide-staff measurement, concurrent water pressure measurement, gain, and offset of the model. The value of O is negative in the present case, because the pressure port of the PPTR is located below the CD level (Fig. 1). The premise is that, if a sufficiently large data set (during a given season) has been used in constructing the model, then application of this model to a much larger time-series of water-pressure data during the same season should provide a realistic estimate of chart-datum-referenced sea level elevation.

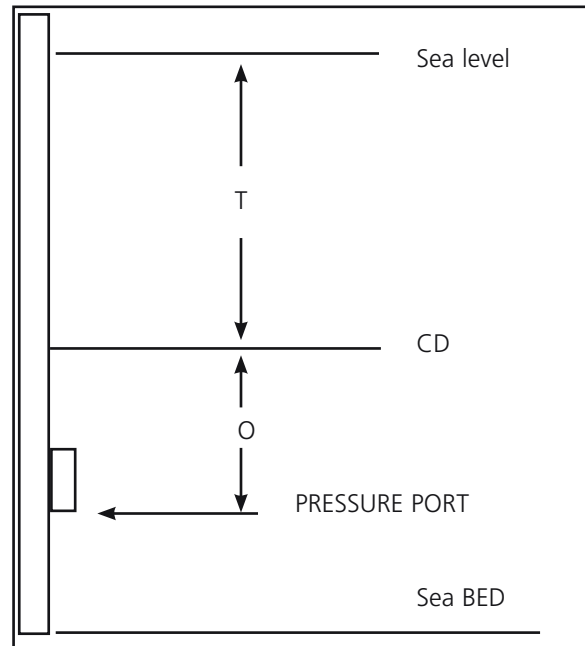

Figure 1. Schematic diagram illustrating the model parameters T and O .

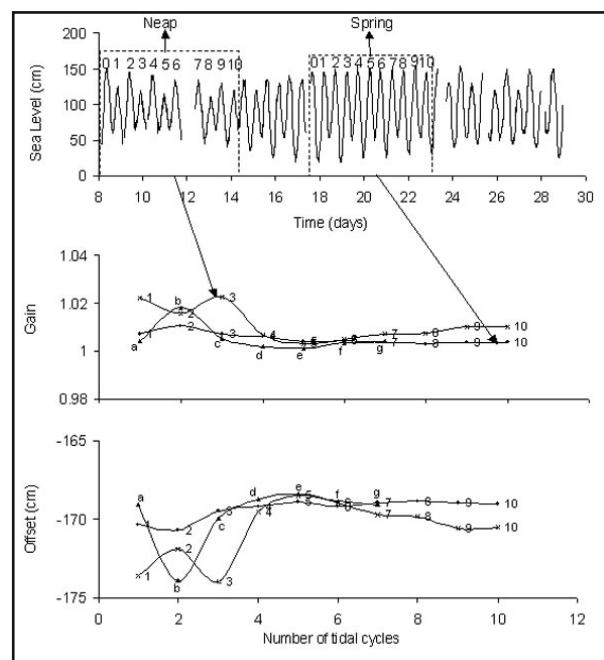

Figure 2. Illustration of optimal number of tidal cycles and their neap/spring relationships in achieving stabilization of model parameters G and O .

Optimization of tide-staff measurements

A bench-mark-levelled tide-staff can be found in every harbour. The Intergovernmental Oceanographic Commission (IOC) of UNESCO has recommended the application of tide-staff measurements for quality control of sea level measurements made from autonomous instrumentation (IOC, 2002). However, no reports are available on the optimal quantum of tide-staff measurements to be made, nor the most appropriate sequence of such measurements in relation to spring/neap cycles for their use in optimizing quality control. Thus, at present, lack of clarity exists as to what constitutes a 'sufficiently large' and 'representative' data set to be used for the construction of the model. In an attempt to find an answer to these questions, we constructed several model equations of the type mentioned above, wherein data sets (acquired at 15-minute intervals) corresponding to differing tidal cycles during neap and spring tides were used. We then examined the optimal number of tidal cycles and their neap/spring relationships in achieving stabilization of the model parameters G and O corresponding to each of these model equations (Figure 2).

In this study, it was observed that, in the case of neap tide measurements (indicated by ¥ on the graphs), even after several tidal cycles, the values of G and O never stabilized (i.e. the values did not lie on a line parallel to the x-axis). However, unlike neap tide, spring tide measurements (indicated by _ on the graphs) provided significantly improved results. In this case, G and O stabilized with the use of the data set corresponding to a 3-tidal cycle (one and half days), and the incorporation of more tidal cycles for the construction of the model did not provide any added benefits in terms of stabilization of G and O. We then examined whether centering the data set on spring tide peak could reduce the size of the data set for construction of the model. With reference to Figure 2; points a, b, c, d, e, f, and g represent, respectively, the results achieved with the use of quarter-hourly data sets acquired at/near

spring tide between points 4–5 (1 cycle), 5–6 (1 cycle), 4–6 (2 cycles), 3–7 (4 cycles), 2–8 (6 cycles), 1–9 (8 cycles), and 0–10 (10 cycles). It is seen that, in relation to several of the G and O values obtained from the models, the use of data sets corresponding to a single cycle that encompasses the largest tidal range (bounded by points 4–5 at spring tide) provided stabilized G and O values (indicated by a on the Gain and Offset graphs). However, data sets corresponding to another adjacent single cycle that represented a much smaller tidal range (bounded by points 5–6 at spring tide) provided G and O values (indicated by b on the Gain and Offset graphs) that differed significantly from the stabilized G and O values. In many cases a single tidal cycle at spring tide may not represent the maximum range of the water column height. This explains why sometimes a data set corresponding to three or more tidal cycles during a given spring tide becomes necessary to achieve stabilization of the model parameters G and O. It may therefore be concluded that the crucial factor, which determines stabilization of the model parameters G and O is the incorporation of data sets from that (those) tidal cycle(s) which encompasses the largest range of water column height during a given spring tide. Figure 3 provides the chart-datum-referenced sea level measurements obtained from Takoradi harbour during the period 1 July 2004 to 30 June 2005 based on the above scheme.

Conclusions

The primary objective of our present studies, based on the GLOSS sea level data from Takoradi harbour, was to examine a method to improve the accuracy of bottom-pressure-based coastal and estuarine sea level measurements. In this method, time-series bottom pressure measurements are translated to chart-datum-referenced sea level elevation through post-processing using a statistically derived mathematical model. This model is constructed from a set of successive periodic (15-minute intervals) bottom pressure measurements over a few tidal cycles during the spring tide, which encompasses the maximum span of water column

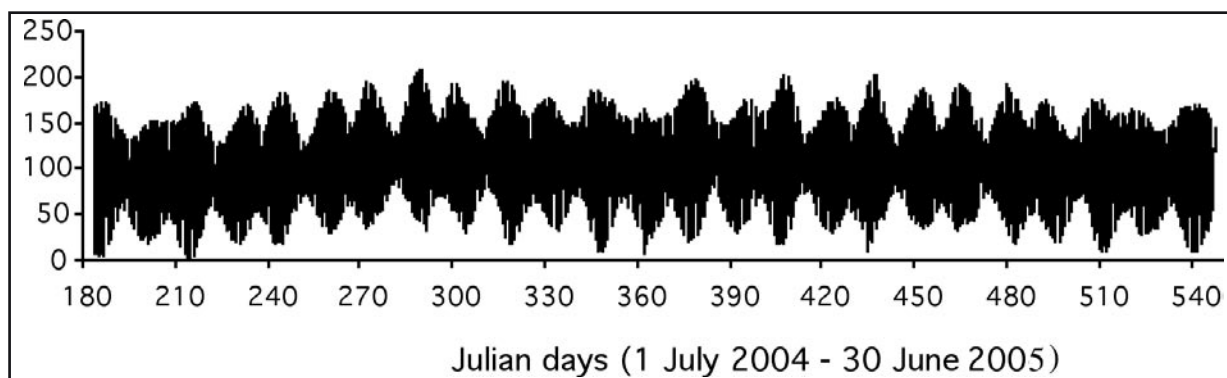

Figure 3. Chart-datum-referenced sea level measurements from Takoradi harbour, Ghana.

height and concurrent benchmark-leveled tide-staff measurements. Unlike in the conventional method, the model provides a chart-datum-referenced sea level record directly from bottom pressure measurements without the use of seawater density measurements. This method is expected to be applicable for all types of water bodies and particularly appropriate for suspended-sediment-laden water bodies whose effective density has been reported to be less than that obtained from conventional measurements.

Acknowledgments

The authors acknowledge the logistic support provided by Mr. J. Wellens-Mensah (AG Director, Hydrological Services Department, Ghana) and Mr. Jean Dotse (Director of Surveys of Ghana).

References

- Joseph, A., Desa, E., Desa, E.S., Smith, D., Peshwe, V.B., Kumar, V., Desa, J.A.E. 1999. Evaluation of pressure transducers under turbid natural waters. *Journal of Atmospheric and Oceanic Technology*, 16 (8) 1150-1155.
- Joseph A., Desa, E., Kumar, V., Desa, E.S., Prabhudesai, R.G., Prabhudesai, S. 2004. Pressure gauge experiments in India. In: S. Holgate and T. Aarup (eds) *IOC Workshop on New Technical Developments in Sea and Land Level Observing Systems (14–16 October 2003)*, Paris, France. IOC Workshop Report No. 193 22-37.

Chilean Sea Level Network

Juan Fierro, Chilean Navy Hydrographic and Oceanographic Service (SHOA)
E-mail: jfierro@shoa.cl

In 1941, the Chilean Navy Hydrographic and Oceanographic Service (SHOA) initiated the establishment of the national tide gauge network with the objective of starting a systematic and permanent recording of the sea surface level along the coast.

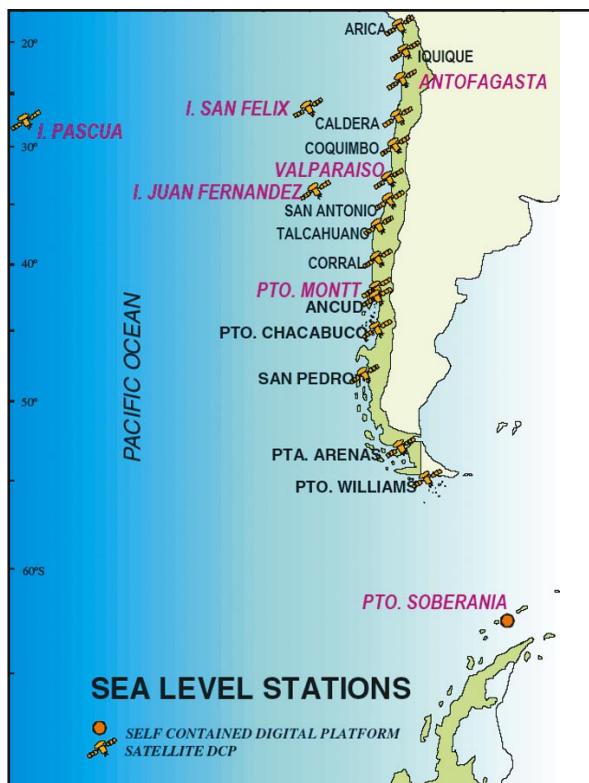

Figure 1. Chilean sea level network.

At the end of 1950, the network consisted of five tide gauge stations, and the experience gained during its deployment and operation was extremely important for a successful extension of the network.

The great length of the Chilean coast and the accessibility problems in some areas have been the main obstacles to extending the network in the short term. However, at the end of 1998, the sea level network comprised 19 permanent tide gauge stations, located on the mainland as well as in some islands and in Antarctica. Considered as a system, the operation of this network has allowed SHOA to provide useful information to mariners sailing in Chilean waters and to contribute to engineering projects associated with coastal-zone management. Moreover, the information



Figure 2. Sea level station configuration.

obtained has been of great value to the national and international scientific communities.

The upgrading initiated in March 1999 considered the deployment of 17 HANDAR model 555C data-acquisition platforms, as shown in Figure 1. The new platforms, with satellite data-transmission capability, replaced the old recording tide gauges, whose operation was based on nitrogen gas pressure. The present tide gauge station's characteristics are shown in Figure 2.

For the comparison of old and new gauges, six months of overlapping (concurrent) operation were considered. During this time, both systems operated in parallel and intercomparisons were performed. Sea level data and ancillary data collected by the sea level network were transmitted via the GOES satellite system. Incoming sea level data were validated using a quality-control package provided by the University of Hawaii. Plots of new computations of yearly residuals showed fewer errors in comparison with previous findings.

The standard configuration of every sea level station included a water-column pressure sensor, an atmo-

spheric pressure sensor, and seawater temperature and air temperature sensors. Recently, an ultrasonic wind sensor was added to some stations on the northern part of the Chilean coast.

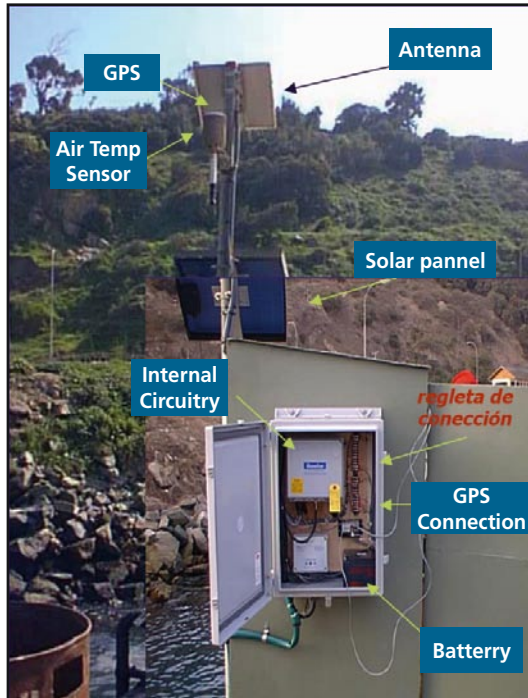

Figure 3. Sea level station components.

The sea level sensor used is a submersible pressure transducer, with an operating range from 0 to 70 g/cm² (equivalent to 13.7 m) of water column. The signal conductor cable holds a ventilation tube that eliminates the atmospheric pressure effect over the water column.

The sea level height is recorded at two-minute intervals and the other environmental parameters once every hour. The main components of the DCP are shown in Figures 3 and 4.

The development of this modern data collection platform (DCP) network has several benefits which may be summarized as:

- Flexible configuration
- Easy installation, adaptable to different structures on the field
- Long autonomy
- Powerful data acquisition software
- Better accuracy: 1 cm with DRUCK sensor complies with GLOSS requirements

Nevertheless, according to the experience accumulated by SHOA, this system has a few drawbacks, summarized as follows:

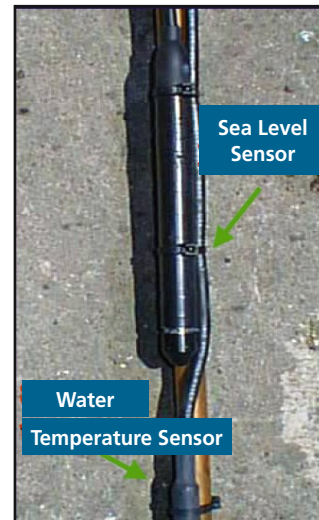

Figure 4. Submerged sensors.

- High cost compared to simpler systems
- Requires continuous maintenance for the DRUCK sensor
- Requires levelling campaigns on a regular basis to ensure accurate data
- Modem communication with each DCP is not reliable

During the first semester of 2005, SHOA has performed further upgrades to its network, by installing a Vaisala Direct Readout Ground Station (DRGS) at SHOA's headquarters at Valparaíso (Figure 5). This DRGS receiver collects information from our remote data collection platforms (DCP). The DRGS is fully user-configurable through the Data Management System (DMS) using a



Figure 5. DRGS antenna at SHOA headquarters.

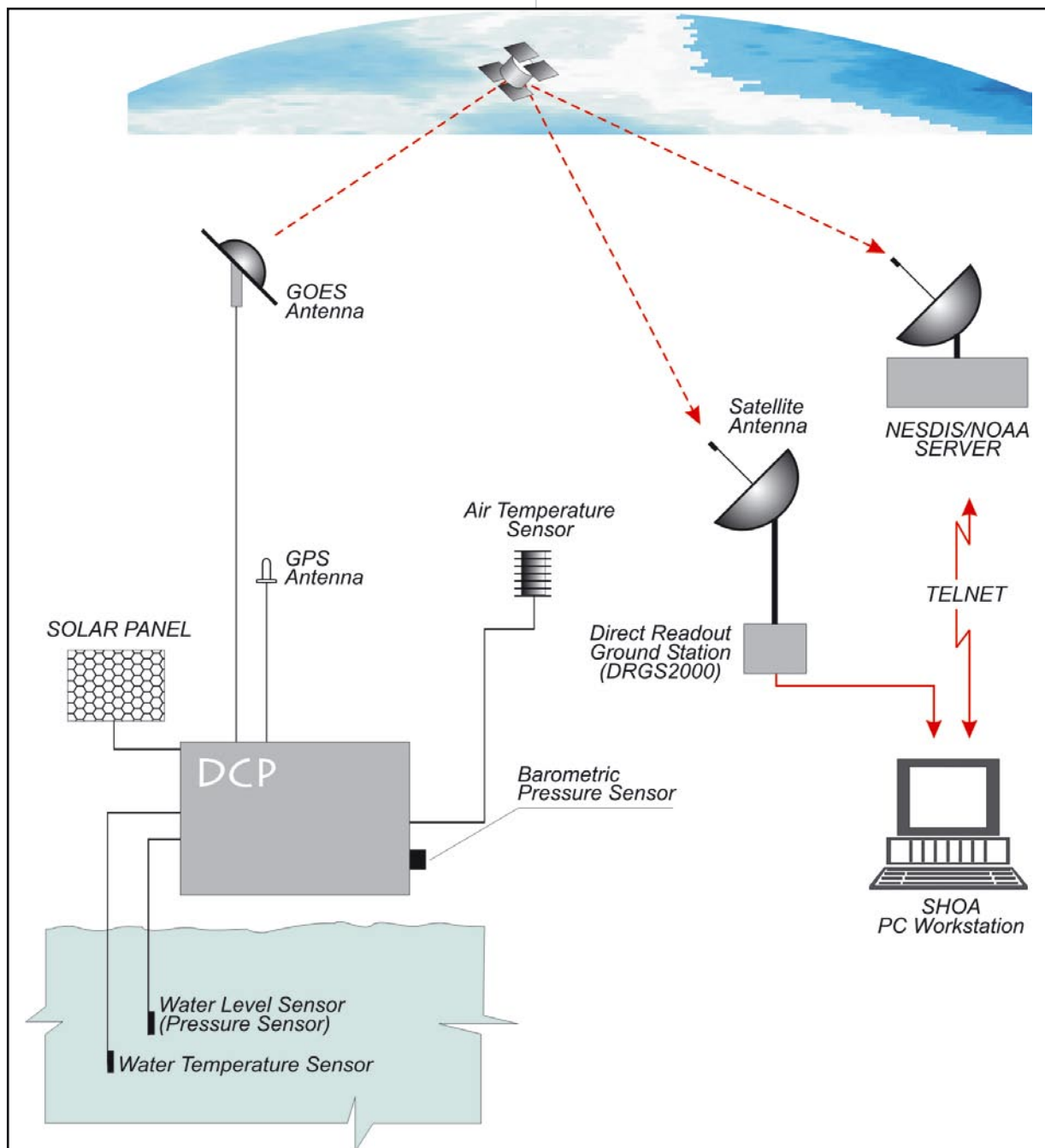

Figure 6. Information flow across SHOA's DCP network.

bi-directional serial interface, which controls the entire system through a Pentium-based computer using Windows 95/98/NT.

The DRGS has greatly improved the information flow from sea level stations to the final user at our headquarters (Figure 6), enhancing the ability to take timely decisions and improving SHOA's cooperation in international warning systems.

One of the main components in the operation of the National Tsunami Warning System is the existing network of sea level stations along the coast of continental Chile and the Pacific islands. The information provided

by the stations is crucial to the determination of the tsunami hazard whenever a big earthquake occurs in the Pacific.

The major upgrades performed in recent years have also increased SHOA's contribution in international studies like the ENSO monitoring network in the Pacific Ocean. The collection of environmental data, such as sea-surface temperature (SST) and mean sea level (MSL) along the Chilean coast, has enhanced our understanding of this important phenomenon which affects several economic activities, such as fisheries and agriculture.

Gauges for Tsunami Warning

Bernie Kilonsky, University of Hawaii Sea Level Center, USA.
E-mail: kilonsky@hawaii.edu

The University of Hawaii Sea Level Center (UHSLC) has been providing high frequency tide gauge data for tsunami warning to the Pacific Tsunami Warning Center (PTWC) for 25 years. This has led to an emphasis on multiple-use platforms that have the stability and accuracy to measure long-term sea level variability and trends, and the range, durability, and sampling capability to monitor tsunamis. Serving this dual purpose has resulted in a robust system; station malfunctions can be detected and addressed quickly given the immediate access to the data, and ongoing maintenance in support of sea level monitoring ensures the sustainability of the stations between infrequent tsunami events. Here we briefly describe the basic configuration used by the UHSLC for a tide gauge station that can also be used for tsunami warning.

Sensors - Since no single sensor is optimal for measuring both mean and high amplitude fluctuating components of sea level, a combination of water level sensors are used. The primary sea level sensor is a pulsed radar, with sampling fast enough (3 minute averages or shorter) to serve also as a secondary tsunami sensor. The primary tsunami sensor is a vented pressure transducer reporting 1 minute or shorter averages. The pressure time series, converted to water level, is usually adequate to fill any short gaps that may occur in the radar record. In many cases, a station with a preexisting float gauge is also retrofitted for tsunami monitoring. In these situations the float gauge is maintained as a third sensor that provides a backup for sea level monitoring. Water level switches and a tide staff are also included to monitor the stability of the data over time.

Power – All UHSLC stations rely on batteries charged by solar panels for power. At many remote sites, local power is not an option. More importantly, local power is susceptible to failure in the event of a local earthquake or tsunami inundation event, in which case it is advantageous to be isolated from the power grid. Most of the UHSLC stations are at low- to mid- latitudes making solar a viable option. This may not be the case at high latitude sites.

Siting - Because tide gauges require a stable platform, most of the UHSLC stations are located on piers or docks within harbors or atoll lagoons. In terms of tsunami monitoring, this has the disadvantage of not sampling the wave signal in an open coast setting. Tsunami amplitudes and frequencies within a protected harbor are likely to be significantly different than along an unprotected coast. This is of particular concern for tsunami modelers who may be trying to assimilate tide gauge data. On the other hand, unprotected sites tend to be exposed to swell and low frequency wave energy that may in some cases mask a small tsunami event or limit the early detection of a larger event. In addition, the station is less likely to be destroyed during a tsunami if it is situated in a harbor. For these reasons, we consider sitting a station within a harbor a better option if the main concern is to determine whether a tsunami threat is present or not.

Communications – The UHSLC tsunami monitoring experience in the Pacific has been in the context of a basin-wide warning system. Given that the Pacific is such a large area, transmitting data from the station to the warning center within an hour or so of collection is typically sufficient for monitoring the basin-wide extent of a tsunami event. As such, the UHSLC has used the GOES satellite in the Pacific, with the transmission of 2-4 minute averages every hour.

Following the December 2004 tsunami, UHSLC is transitioning to 1 minute averages transmitted every 15 minutes for basin wide monitoring. This transmission rate has been accomplished using the Japanese Meteorological Agency (JMA) and EUMETSAT geostationary satellites in the Indian Ocean, and the GOES in the Pacific. For stations located within a 1-hour travel time of a known tsunami generation site, 15 second sampling with a 5-minute transmission cycle is under consideration. At present, this may be feasible on the GOES system but not for stations using either the JMA or EUMETSAT downlinks. For these stations, and in support of partners installing national tsunami warning systems, UHSLC plans to use the INMARSAT BGAN system. This application is currently under development in the Indian Ocean.

ODINAFRICA Tide Gauge Specification August 2005

Peter Foden, Proudman Oceanographic Laboratory, Liverpool, UK. E-mail: prf@pol.ac.uk

The following lists technical details of UNESCO–IOC funded radar and pressure sensor tide gauges that are being procured by POL for installation at sites in Africa as part of the first phase of the ODINAFRICA project. The instrumentation consists of four basic parts:

- **Sensors** – the primary sensor is an OTT Kalesto radar gauge measuring height above sea level, and secondary sensors are OTT PS1 pressure sensors measuring water pressure and temperature at two points in the water column.
- **Housing** – the fibreglass instrumentation cabinet houses the mains power supply, 27 Ah lead–acid rechargeable battery, OTT HDR-DCP satellite telemetry unit which sends data through METEOSAT, Logosens2 data logger, 2,400 baud line-powered modem and lightning suppression for the power and data lines.
- **Telemetry** – yagi antenna and 10-m cable for data telemetry and GPS antenna for the integrated receiver system in the HDR-DCP.
- **Data logging** – the principal data-retrieval system is by satellite telemetry, but the Logosens2 data logger has limited capacity to store the measured sensor data. Access to these data is by local operator or via dial-up modem; set-up and maintenance can also be carried out via the modem link.

The radar sensor needs to be fitted to a locally-manufactured support arm (specification can be supplied by POL or there is an OTT version available), a site-determined length of 4-core cable is provided enabling the sensor to be located a distance away from the instrumentation cabinet, if required. The pressure sensors require to be fitted in a stilling well and installation kits for this purpose are included.

The instrument cabinet is meant to be wall-mounted and should be inside a building that has a reliable mains power supply and telephone connection.

The HDR-DCP antenna needs to have as good a view of the sky and horizon as possible and should be mounted away from physical obstructions, such as metalwork and structures, where possible.

Description of operation

By using the OTT HDR-DCP satellite telemetry unit, accurate real-time data are available from the integrated GPS receiver. This means that the system does not need to be set up after switch-on and that time measurement is always accurate to ± 1 s.

The two pressure sensors are differential (air-pressure compensated) sensors. One measures sub-surface pressure and the other is positioned at approximately MSL to provide a form of 'B' gauge datum control checking both for the first pressure sensor and for the Kalesto (see explanation of 'B' gauges in the present Manual).

The Kalesto radar sensor and the pressure sensors are interrogated every minute by the Logosens2 data logger and the data are recorded. The one-minute values can be averaged to whatever time interval is required, e.g. six-minute averages, and sent to the HDR-DCP for transmission at the allotted time. Alternatively, data can be recovered via data modem connection. The tide gauge has a back-up supply that is capable of keeping the whole system going for approximately two days without mains power.

Note that this equipment is similar to that provided by IOC and POL to two sites in Mozambique, and installed in early 2005 by the South African Navy Hydrographic Office. In that set-up, the METEOSAT DCP was replaced by Orbcomm telemetry which provides relatively cheap data transmission but with variable latency (see section 5, above).

TideTool – A Software Package to Display and Decode Sea Level Data Transmitted over the WMO Global Telecommunications System

Laura Kong, International Tsunami Information Centre, Hawaii, USA. E-mail: l.kong@unesco.org

The software package TideTool provides end users with the ability to decode, display and manipulate sea level data broadcast over the Global Telecommunications System (GTS) of the World Meteorological Organization (WMO). The software utilizes the Tcl/Tk software package, specifically the BLT extension. Tcl/Tk is an open source, platform-independent software package offering a powerful shell programming language and graphical toolkit.

The software application was developed by the US NOAA NWS Pacific Tsunami Warning Center to provide an operational tool for real-time continuous tsunami monitoring in the Indian Ocean. Its primary users would be national meteorological and hydrological services (NMHS), or other agencies with a downlink from the GTS or to a data file containing those data formatted in a similar manner. It has been tested under Linux, Windows 2000 and Windows XP environments in Indonesia and Malaysia. A Manual is available providing information on its installation and use. The tool and documentation are available from the ITSU website: <http://www.tsunamiwave.info/operations>

TideTool is station specific, but can be easily modified for changes in formatting and the addition of additional sea level stations when needed. The primary use of this software is as an operational programme run by tsunami warning centres, or other operational centres, which need to continuously monitor sea levels. Mouse-clickable functions include the expansion of the time-series, and measurement of the arrival time, wave height and wave period from the incoming signal.

Requirements

To decode and display the data, the following are required:

- Computer running Tcl/Tk software with BLT extension
- Sea level data that are continuously archived into a data file
- Tide.tcl software

Computer and Tcl/Tk software with BLT extension

The TideTool software requires the installation of the Tcl/Tk software package and the BLT extension, both of which are freely available for download and easy to install. TideTool has been installed and tested under Unix, Linux, Windows XP and Windows 2000 operating systems. Use on other platforms is possible, as it only depends on the Tcl/Tk and BLT softwares being available. The software does not require heavy computing power, and can thus run easily on a Pentium III or higher PC system.

Sea level data

The input is assumed to be a continuously appended, ASCII-text flat file containing transmissions of data from different sea level stations in the Indian Ocean. Each station and its data transmission are described by a unique set of parameters, including a Satellite Product Headers, Station Platform, method of transmission and transmission time, and file formats (Figure 1).

```
SWIO40 RJTD 250015
:ENB 1 #1 M 3908 3908 3910 3909 3911 3909 3912
3910 3913 3913 3917 3917 3917 3917 3915 3918
3914 3917 3912 3913 3913 3913 3912 3913 3911
3908 3908 3905 3909 :ENC 1 #2 3409 3410 3411 3411
3413 3419 3419 3420 3419 3415 3414
3418 3411 3408 3410 3409 3409 3408 3409 3409
3414 3413 3409 3414 3414 3410 3412 3409 3410
3413 :BATTLOAD 0 12.83 :NAME=

91642 46/// /1205 10296 40080 22200 00287
555 77744 A0102 516'3 60029 6315B 03024 83030
00A07 02548 02901 29631 6B090 24520 2400A 13025
90036 00297 317B1 50240 60310 0A190 26230 38002
96317 B2102 37103 100A2 50266 50330 02973 18B27
02331 02800 A3102 70103 10029 8318B 33022 92026
00A37 02736 03401 29831 8B390 22570 2801A 43027
66028 00299 319B4 50222 50230 0A490 27960 34002
98319 B5102 19202 901A5 50282 20380 02983 19B57
02163 03200 BV289 13451 41249 C0501 22080 00070
23677 44777=

^^33487552
206011307M94168411DZpQ^@@@r}OuW@1[Am@~@BsB
YBAG@BrBYBzAM@BqBZCUAB@BoBZCmA@@BmBZDM
AI@BIBZDrAG@BIBZD?AD@BkBZETAL@BjBZEwAGABhBZ"
@qv@oL3@[DvAI4B]5Ad6a'=OE0uVW>ZAnA]BYBkCRCqC
sDWDnER"@us@soOuVV>YCqC?DBCtDSD[DnDxEGEa"@
wh@wB_OLAoP 50+1NN 116W
```

Figure 1. Sample of transmissions from field station Data Collection Platform (DCP) in formats used by the University of Hawaii Sea Level Center, by Australia National Tidal Centre, and the US National Ocean Service, respectively.

In general, sea level data are digitized and sampled at the field station. Ideally, the data transmitted for tsunami monitoring will be 1-minute (or better) averaged data values that are transmitted at least every 15 min; currently, stations transmit every 10–60 minutes and data averages are at 1 to 4-minute sampling intervals. The data are transmitted over a number of different satellites to regional telecommunications hubs of the WMO,



Figure 2. Transmission from the data collection platform at the field station to the warning centres.

and onwards to customers such as the Pacific Tsunami Warning Center, the Japan Meteorological Agency, and to any requesting national hydrological agency (Figure 2).

In the Indian Ocean, the primary satellites used for transmission from the field stations are the Japanese GMS for the eastern Indian Ocean and the EUMETSAT operational satellite system for the central and western Indian Ocean. The PTWC receives its data through the USA GOES satellite system. The satellites are part of the GTS. The GTS is a semi-private, reliable communicationssystem supported by the 187-member WMO for the transmission of environmental data, information messages and warnings. The GTS is the primary means by which the PTWC receives sea level data and issues tsunami warnings.

TideTool

The programme is started by typing bltwish Tide.tcl. It decodes the received sea level data that are found in a single data-logging file, creates individual station files containing the decoded data, and starts a graphical user interface display that allows each station to be displayed as a plot (Figure 3).



Figure 3. GUI showing all stations that were decoded.

Each time-series can be manipulated using a mouse to zoom and pick an amplitude or wave period (Figure 4).

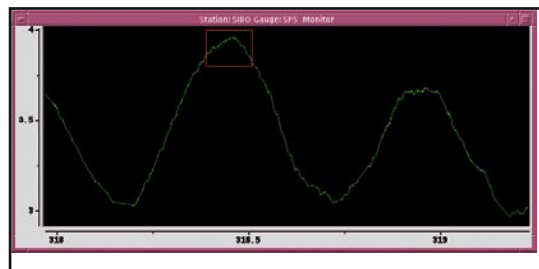

Figure 4. Sea level time-series plot. A mouse is used to select the part which should be enlarged to pick the arrival time.

Tide.tcl will operate continuously once started. It will check every 20 s to see if any new data have arrived, and if so, it will decode and update the station time-series file that is plotted. When Tide.tcl is started, it will read data from the current day data log. Tide.tcl will keep up to 24 hours of data. As more data arrive beyond what Tide.tcl is supposed to hold, it will discard the older data to make room for the new. For each station, two gauges are decoded. The gauge code is three letters, where prs stands for pressure sensor, bub indicates bubbler etc.

For further information and questions, please contact the IOC International Tsunami Information Centre (itic.tsunami@noaa.gov) or the Pacific Tsunami Warning Center (stuart.weinstein@noaa.gov).

IOC Manuals and Guides

No.	Title
1 rev. 2	Guide to IGOSS Data Archives and Exchange (BATHY and TESAC). 1993. 27 pp. (English, French, Spanish, Russian)
2	International Catalogue of Ocean Data Station. 1976. (Out of stock)
3 rev. 3	Guide to Operational Procedures for the Collection and Exchange of JCOMM Oceanographic Data. Third Revised Edition, 1999. 38 pp. (English, French, Spanish, Russian)
4	Guide to Oceanographic and Marine Meteorological Instruments and Observing Practices. 1975. 54 pp. (English)
5 rev.	Guide for Establishing a National Oceanographic Data Centre, 1997. 42 pp. (English)
6 rev.	Wave Reporting Procedures for Tide Observers in the Tsunami Warning System. 1968. 30 pp. (English)
7	Guide to Operational Procedures for the IGOSS Pilot Project on Marine Pollution (Petroleum) Monitoring. 1976. 50 pp. (French, Spanish)
8	(Superseded by IOC Manuals and Guides No. 16)
9 rev.	Manual on International Oceanographic Data Exchange. (Fifth Edition). 1991. 82 pp. (French, Spanish, Russian)
9 Annex I	(Superseded by IOC Manuals and Guides No. 17)
9 Annex II	Guide for Responsible National Oceanographic Data Centres. 1982. 29 pp. (English, French, Spanish, Russian)
10	(Superseded by IOC Manuals and Guides No. 16)
11	The Determination of Petroleum Hydrocarbons in Sediments. 1982. 38 pp. (French, Spanish, Russian)
12	Chemical Methods for Use in Marine Environment Monitoring. 1983. 53 pp. (English)
13	Manual for Monitoring Oil and Dissolved/Dispersed Petroleum Hydrocarbons in Marine Waters and on Beaches. 1984. 35 pp. (English, French, Spanish, Russian)
14	Manual on Sea-Level Measurements and Interpretation.
	Vol. I: Basic Procedure. 1985. 83 pp. (English, French, Spanish, Russian)
	Vol. II: Emerging Technologies. 1994. 72 pp. (English)
	Vol. III: Reappraisals and Recommendations as of the year 2000. 2002. 55 pp. (English)
	Vol. IV: An Update to 2006. 2006. 78 pp. (English)
15	Operational Procedures for Sampling the Sea-Surface Microlayer. 1985. 15 pp. (English)
16	Marine Environmental Data Information Referral Catalogue. Third Edition. 1993. 157 pp. (Composite English/French/Spanish/Russian)
17	GF3: A General Formatting System for Geo-referenced Data
	Vol. 1: Introductory Guide to the GF3 Formatting System. 1993. 35 pp. (English, French, Spanish, Russian)
	Vol. 2: Technical Description of the GF3 Format and Code Tables. 1987. 111 pp. (English, French, Spanish, Russian)
	Vol. 3: Standard Subsets of GF3. 1996. 67 pp. (English)
	Vol. 4: User Guide to the GF3-Proc Software. 1989. 23 pp. (English, French, Spanish, Russian)
	Vol. 5: Reference Manual for the GF3-Proc Software. 1992. 67 pp. (English, French, Spanish, Russian)
	Vol. 6: Quick Reference Sheets for GF3 and GF3-Proc. 1989. 22 pp. (English, French, Spanish, Russian)
18	User Guide for the Exchange of Measured Wave Data. 1987. 81 pp. (English, French, Spanish, Russian)
19	Guide to IGOSS Specialized Oceanographic Centres (SOCs). 1988. 17 pp. (English, French, Spanish, Russian)
20	Guide to Drifting Data Buoys. 1988. 71 pp. (English, French, Spanish, Russian)
21	(Superseded by IOC Manuals and Guides No. 25)
22	GTSP Real-time Quality Control Manual. 1990. 122 pp. (English)
23	Marine Information Centre Development: An Introductory Manual. 1991. 32 pp. (English, French, Spanish, Russian)

No.	Title
24	Guide to Satellite Remote Sensing of the Marine Environment. 1992. 178 pp. (English)
25	Standard and Reference Materials for Marine Science. Revised Edition. 1993. 577 pp. (English)
26	Manual of Quality Control Procedures for Validation of Oceanographic Data. 1993. 436 pp. (English)
27	Chlorinated Biphenyls in Open Ocean Waters: Sampling, Extraction, Clean-up and Instrumental Determination. 1993. 36 pp. (English)
28	Nutrient Analysis in Tropical Marine Waters. 1993. 24 pp. (English)
29	Protocols for the Joint Global Ocean Flux Study (JGOFS) Core Measurements. 1994. 178 pp. (English)
30	MIM Publication Series: Vol. 1: Report on Diagnostic Procedures and a Definition of Minimum Requirements for Providing Information Services on a National and/or Regional Level. 1994. 6 pp. (English) Vol. 2: Information Networking: The Development of National or Regional Scientific Information Exchange. 1994. 22 pp. (English) Vol. 3: Standard Directory Record Structure for Organizations, Individuals and their Research Interests. 1994. 33 pp. (English)
31	HAB Publication Series: Vol. 1: Amnesic Shellfish Poisoning. 1995. 18 pp. (English)
32	Oceanographic Survey Techniques and Living Resources Assessment Methods. 1996. 34 pp. (English)
33	Manual on Harmful Marine Microalgae. 1995. (English) [superseded by a sale publication in 2003, 92-3-103871-0. UNESCO Publishing]
34	Environmental Design and Analysis in Marine Environmental Sampling. 1996. 86 pp. (English)
35	IUGG/IOC Time Project. Numerical Method of Tsunami Simulation with the Leap-Frog Scheme. 1997. 122 pp. (English)
36	Methodological Guide to Integrated Coastal Zone Management. 1997. 47 pp. (French, English)
37	Post-Tsunami Survey Field Guide. First Edition. 1998. 61 pp. (English, French, Spanish, Russian)
38	Guidelines for Vulnerability Mapping of Coastal Zones in the Indian Ocean. 2000. 40 pp. (French, English)
39	Cancelled
40	Guidelines for the Study of Shoreline Change in the Western Indian Ocean Region. 2000. 73 pp. (English)
41	Potentially Harmful Marine Microalgae of the Western Indian Ocean Microalgues potentiellement nuisibles de l'océan Indien occidental. 2001. 104 pp. (English/French)
42	Des outils et des hommes pour une gestion intégrée des zones côtières - Guide méthodologique, vol.II/ Steps and Tools Towards Integrated Coastal Area Management – Methodological Guide, Vol. II. 2001. 64 pp. (French, English; Spanish)
43	Black Sea Data Management Guide (Under preparation)
44	Submarine Groundwater Discharge in Coastal Areas – Management implications, measurements and effects. 2004. 35 pp. (English)
45	A Reference Guide on the Use of Indicators for Integrated Coastal Management. 2003. 127 pp. (English). ICAM Dossier No. 1